

**HELPEBS
CONTROLS**

HYDRAULIC CYLINDERS EH SERIES

High quality range of 210bar (3,000psi) tie rod cylinders from 25mm bore to 200mm bore



PERFORMANCE UNDER PRESSURE
AGAIN. AND AGAIN. AND AGAIN.

Available mountings and where to find them

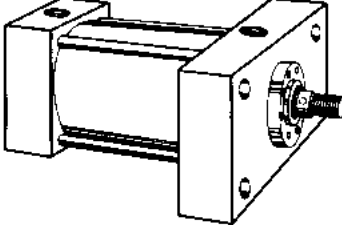
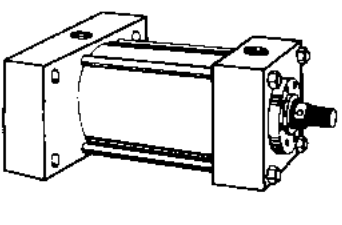
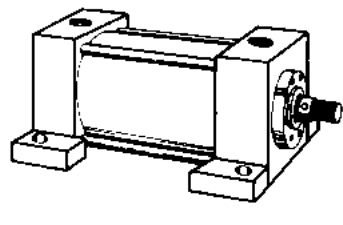
<p>Front Head Flange Mount – Style FHF</p>  <p>(ISO style ME5) page 16</p>	<p>Rear Head Flange Mount – Style RHF</p>  <p>(ISO & DIN style ME6) page 16</p>	<p>Side Lug Mount – Style SL</p>  <p>(ISO & DIN style MS2) page 16</p>
---	--	---

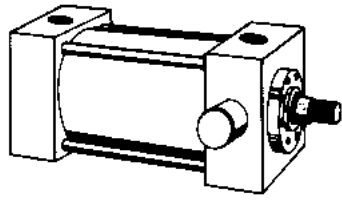
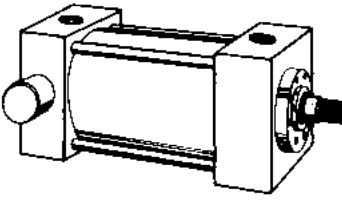
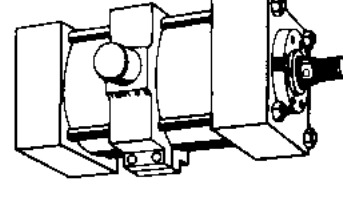
<p>Trunnion Front Mount – Style TF</p>  <p>(ISO style MT1) page 18</p>	<p>Trunnion Rear Mount – Style TR</p>  <p>(ISO style MT2) page 18</p>	<p>Trunnion Mount – Style T</p>  <p>(ISO & DIN style MT4) page 18</p>
---	--	--

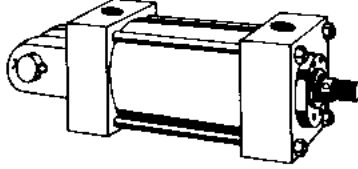
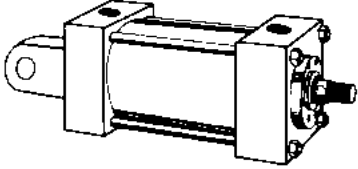
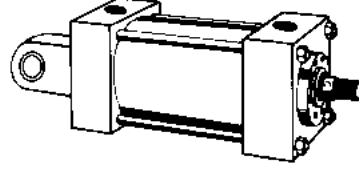
<p>Clevis Mount – Style C</p>  <p>(ISO style MP1) page 20</p>	<p>Pivot Mount – Style P</p>  <p>(ISO style MP3) page 20</p>	<p>Pivot Mount with Spherical Bearing – Style SBp</p>  <p>(ISO & DIN style MP5) page 20</p>
---	---	--

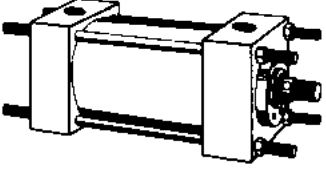
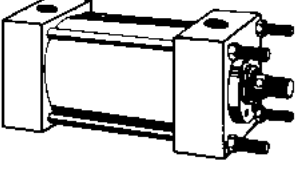
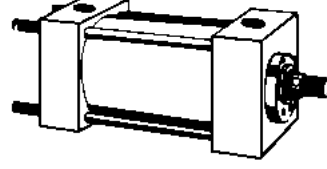
<p>Tie Rods Extended Both Ends – Style BX</p>  <p>(ISO style MX1) page 22</p>	<p>Tie Rods Extended Head End – Style FX</p>  <p>(ISO style MX3) page 22</p>	<p>Tie Rods Extended Cap End – Style RX</p>  <p>(ISO style MX2) page 22</p>
--	---	--

Double Rod Extension

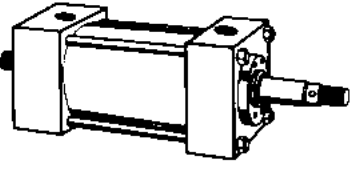

Available in all mounts except "RHF", "C" and "P" page 24

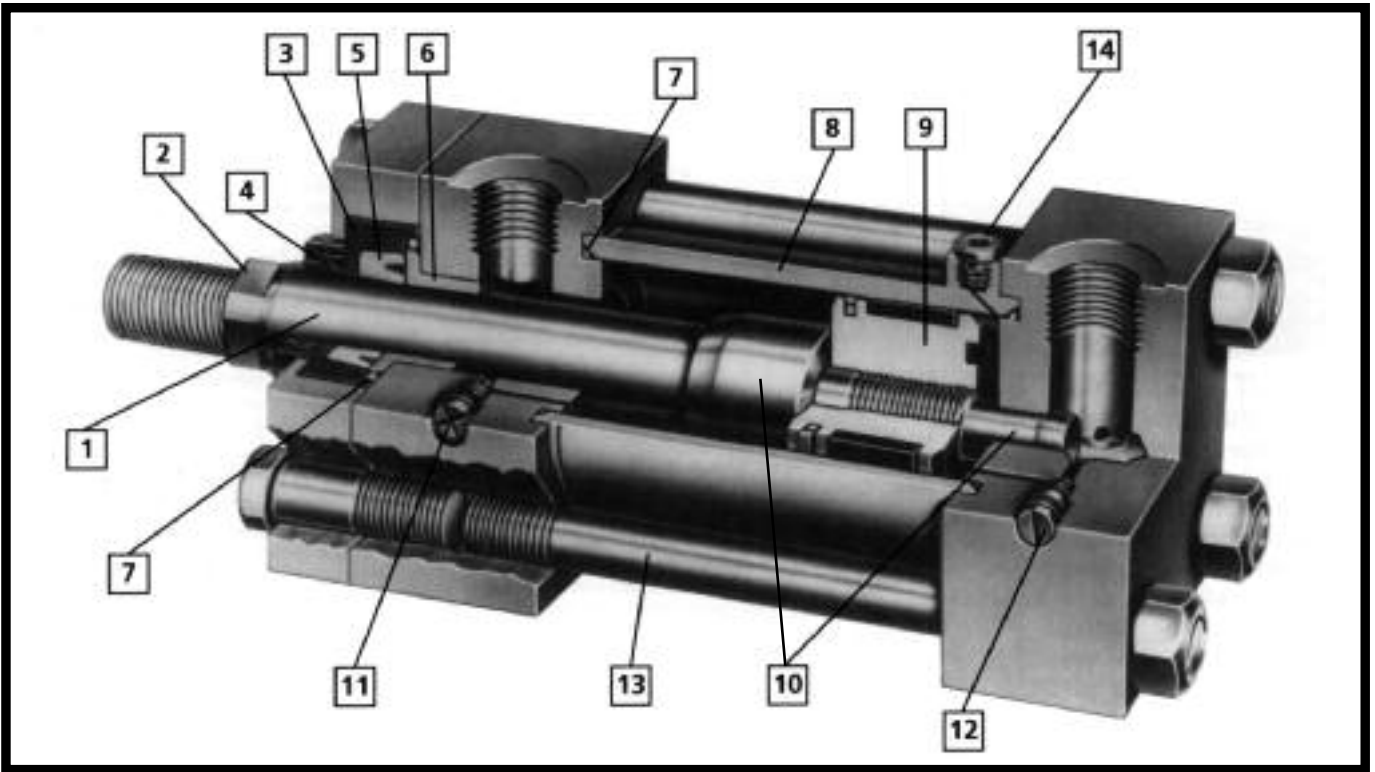

1 Piston Rod

Piston rods upto and including 100 diameter have a minimum expected yield of 690 N/mm². They are case hardened to 50-60 Rockwell "C" to a depth of .75 to 1.5 for damage resistance. They are then hard chrome plated for wear and corrosion resistance. Larger diameter rods have an expected minimum yield of 380 to 415 N/mm² depending on diameter and are hard chrome plated.

2 Wrench Flats

Four wrench flats are provided as standard for easy attachment on all rod diameters.

3 Rod Gland

Easily removable for replacement of rod packings and wiper. In most cases it is not necessary to demount or disassemble the cylinder. Easier to service since, on removal of the ductile iron gland, the piston rod remains supported by the separate rod bearing.

4 Rod Wiper

Synthetic wiper is designed to wipe off abrasive dust and contaminants on the retract stroke to ensure long life for packings, rod bearing, and piston rod. Where the rod will be exposed to gummy materials such as "road tar", a metallic rod scraper is available.

5 Rod Seal

The polyurethane rod seal has a unique design which incorporates the optimum sealing properties of a "U" configuration with the elastomeric properties of a compression-type seal. The polyurethane material was selected for toughness, abrasion resistance, and the ability to resist extrusion under rough service conditions.

6 Rod Bearing

High load bearing bronze piloted into the head. Located inboard of the seals to ensure a well lubricated bearing for the fastest cycling applications. It need not be removed for rod seal replacement.

7 Static Seals

Pressure activated "O" ring seals are used at rod gland and tube ends. Located to eliminate extrusion and to provide positive leak tight seal.

8 Tube

The steel tube is honed to a 0.4 micro metres R_a max finish for low friction and long seal and piston bearing life. Tube ends are machined on the O.D. concentric with the I.D. They are confined by the close tolerance machining of the head and cap which provides greater hoop strength.

9 Pistons and Piston Seals

All pistons are machined from a fine grain alloy cast iron. They are threaded directly onto the piston rod, torqued and sealed. **The special piston seal** is an endless glass filled Teflon material with an "O", ring expander. One or more (depending on bore size) bronze filled Teflon bearing strips are also employed on this type piston to eliminate metal-to-metal contact. This type of piston offers long life, low friction, near zero leakage, and great tolerance for side loading. It can be used successfully on virtually any application and is offered as standard at no extra cost.

10 11 12 Cushions

Cushion pistons (10) are tapered to provide gradual deceleration and eliminate shock upon entrance. The adjusting screw with fine threads (11) provides a wide range of adjustment. It is interchangeable with the ball check (12) permitting field changes of position. Neither the adjusting screw nor ball check plug project beyond the head or cap surface and are held captive by a retaining ring.

13 Tie Rod Construction

Maximum strength is obtained through a prestressed tie rod assembly. The use of high strength steel tie rods eliminates axial loading of tubes and permits higher shock loading.

14 Air Bleeds (Optional)

When required, air bleeds are located where they can be employed most successfully - at the tube and head juncture. The straight thread plugs are equipped with metallic "O" rings so they can be used repeatedly with a good seal every time.

Why a Slipper Seal Piston?

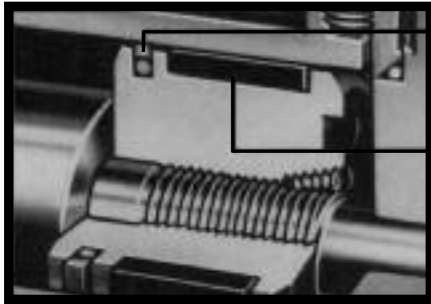

Glass filled Teflon seal
"O" ring expanded

Bronze filled
Teflon bearing strip

BECAUSE IT IS NEEDED!!!!
For years there has been a demand for a hydraulic cylinder piston that exhibited the long life of cast iron rings, the leak-tight sealing of cup seals, and the low friction of Teflon. A piston that would tolerate considerable sideloading without galling or scoring the tube; that would permit easy, but infrequent, maintenance, and would be economically feasible. A near perfect piston for virtually any application. The Slipper Seal Piston, standard on the EH Series, meets these requirements to a degree that is astounding ... and at no extra cost!

Near Zero Leakage

A completely honest statement of facts causes us to use this term. We know of no dynamic seal that is completely leak-tight under ALL operating conditions, but for all practical purposes, the slipper seal is leaktight. Since the higher the pressure, the better the seal, we conducted some of our Slipper Seal tests under low pressures to simulate the worst operating conditions. A good example was the testing of a 152 bore cylinder with trapped pressure of only 1.2 bar. The leakage past the piston permitted average movement of 0.25 mm per 24 hours. That represents an average piston leakage of 2.60 cu. mm per min. This test was conducted over 13 days. Other tests with pressures ranging from 35 to 500 bar showed no leakage whatever.

Long Life – Low Friction

The two are closely related. Friction causes wear which determines life. We cannot state how long a Slipper Seal will last because the life of a dynamic seal depends on too many operational and environmental conditions. We can state, however, that both laboratory and field test have demonstrated a longevity that far exceeds any seal we have tested or used with the possible exception of metallic rings. Although this amazing new type of piston has been introduced as a special option by our competitors, we have been using the Slipper Seal piston for over twenty years on standard cylinders.

No Metal-To-Metal Contact

The use of the Slipper Seal and the bronze filled Teflon bearing strip eliminates metal-to-metal contact between the piston and the tube. This feature alone will resolve many problems experienced by cylinder users.

Results? At no additional cost, you can obtain a cylinder that will give you outstanding service on all normal applications as well as holding or locking circuits, servo circuits, modulating operations, side loaded conditions, rapid cycling operations, and most other problem applications.

FLUIDS AND TEMPERATURES

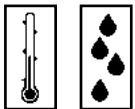

Temperatures

Standard cylinders may be operated at temperatures of -45 to +90°C. For temperatures over 90°C consult the factory for specific recommendations giving operating temperature, source and characteristics of the heat, medium and cycle time. It should be noted that many seal compounds exhibit reduced life as the temperature nears their stated limit. In such applications, it is a good practice to specify high-temperature seals to assure long, satisfactory life.

Fluids

Seal materials employed in standard EH Series cylinders are Buna-N, Polyurethane and Teflon. As such, standard cylinders are particularly suited for use with any good grade petroleum base hydraulic oil. For normal temperature ranges, an oil having a viscosity range of 250-300 S.S.U. at 38°C is recommended. The oil should be maintained at SAE Level 3-4 cleanliness, normally accomplished with a 10 micron

filtration system. Standard seals are also compatible with most Water-Glycol and Water-Oil Emulsion fluids with temperatures limited to a maximum of 60°C. Whenever there is a question of compatibility, contact the factory or the fluid manufacturer. NEVER change system fluid or MIX fluids until a careful check as to compatibility has been made.

Fire Resistant Fluids such as Phosphate Esters and Chlorinated Hydrocarbons require special seal compounds. These can be supplied in lieu of the standard seals at a moderate extra charge. The specific fluid and/or seal compounds should always be given on your order.

Cylinders to be operated with raw water as the fluid medium require special plating and/or special materials. There are two general classifications of cylinders made for use with water: (1) Water-Fitted Cylinders and (2) Water-Hydraulic Cylinders.

(1) Water-Fitted Cylinders are standard cylinders that have been adapted for raw water service by plating the internal metal surfaces. This usually consists of nickel

plating the head, cap and piston and hard chrome plating the tube I.D. While this is the least expensive method of provisioning a cylinder for water service, it is frequently inadequate for long, trouble-free service. Because water conditions vary greatly, we cannot accept responsibility for water-fitted cylinders where failure is caused by corrosion, electrolysis or mineral deposits. When a customer has had experience with local water conditions and finds waterfitted cylinders to work well, he should continue to specify them. If such is not the case, it is recommended that the use of Water-Hydraulic Cylinders be seriously considered.

(2) Water-Hydraulic Cylinders are cylinders designed and manufactured specifically for water service. Non-corrosive materials, such as brass, bronze and stainless steel are used instead of plating. While the initial cost is higher, this type of cylinder is invariably the least expensive in the long run. When requirements exist, request a quotation.

FLUIDS AND TEMPERATURES

Standard EH Cylinders Without Modifications Can Be Used With Water Base Fluids to 60°C.									
Compatibility Chart for Some Fluids and Seal Compounds									
Fluid Name	Mil. Spec.	Trade Name	Type of Seal Compound						
			Buna-N	Butyl	Poly-ure'ne	Neo-prene	EP	Viton®	Teflon®
Brake Fluid			U	U	U	U	R	U	R
Gasoline			R	U	U	U	U	R	R
Transmission Fluid (ATF)			R	U	R	S	U	R	R
Petroleum Base	MIL-H-6083	Preservative Oil	R	U	R	R	U	R	R
Petroleum Base	MIL-H-5606	Aircraft Hydraulic Fluid	R	U	R	U	U	R	R
HWBF (95-5)			R	U	*R	R	U	M	R
Water-Glycol		Houghto-Safe 600 Series	R	S/M	*R	S	R	R	R
		Houghto-Safe 500 Series	R	R	*R	S	R	R	R
	MIL-H-22072	Houghto-Safe 271	R	S	*R	S	R	S	R
		Unicon Hydrolube-J4	R	R	*R	S	R	R	R
		Celluguard	R	R	*R	R	R	R	R
Water/Oil Emulsion		Houghto-Safe 5000 Series	R	U	*R	S	U	R	R
		Gulf FR	R	U	*R	S	U	R	R
		Iris 902	R	U	*R	S	U	R	R
		Pyrogard C & D	R	U	U	S	U	R	R
Water-Soluble Oil			R	M	*R	S	R	R	R
Phosphate Ester		Houghto-Safe 1000 Series	U	R	U	U	R	R	R
	MIL-H-19457B	Houghto-Safe 1120	U	R	U	U	R	R	R
		Fyrquell (Cellulube)	U	R	U	U	R	R	R
		Pyrogard 42, 43, 53, 55, 190, 600	U	R	U	U	R	R	R
		Skydrol 500 Type 2	U	S	U	U	R	U	R
		Skydrol 7000 Type 2	U	R	U	U	R	S	R
		Pydraul 312C, 230C, 540C	U	U	U	U	U	R	R
		Pydraul 10E	U	R	U	U	R	U	R
		Pydraul 29ELT, 30E, 50E, 65E	U	R	U	U	R	R	R
Chlorinated Hydrocarb		Pydraul A-200	U	U	U	U	U	R	R
Silicate Ester		OS-45 Types 3 & 4	S	U	U	R	U	R	R
	MLO-8200	Oronite 8200	S	U	R	R	U	R	R
	MLO-8515	Oronite 8515	S	U	R	R	U	R	R
	MIL-H-8446B	Brayco 846	S	U	R	R	U	R	R

R = Recommended S = Satisfactory M = Marginal U = Unsatisfactory * Maximum Temperature 60°C

NOTE: The above material is for general information and should not be construed as a warranty or representation for which legal responsibility is assumed.

® Registered Trade Mark.

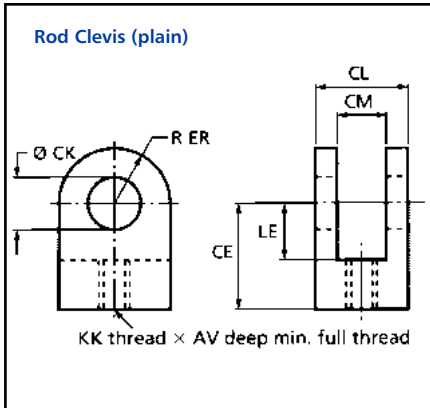

Rod Clevis									
Part Number	AV	CE	CK	CL Max.	CM	ER Max.	KK	LE	Matching Eye Mtg Bracket
CLS-23001	14	32	10	26	12	12	M10 X 1.25	15	MBP-20001
CLS-23002	16	36	12	34	16	17	M12 X 1.25	19	MBP-20002
CLS-23003	18	38	14	42	20	17	M14 X 1.5	19	MBP-20003
CLS-23004	22	54	20	62	30	29	M16 X 1.5	32	MBP-20004
CLS-23005	28	60	20	62	30	29	M20 X 1.5	32	MBP-20005
CLS-23006	36	75	28	83	40	34	M27 X 2	39	MBP-20006
CLS-23007	45	99	36	103	50	50	M33 X 2	54	MBP-20007
CLS-23008	56	113	45	123	60	53	M42 X 2	57	MBP-20008
CLS-23009	63	126	56	143	70	59	M48 X 2	63	MBP-20009
CLS-23010	85	168	70	163	80	78	M64 X 3	82	MBP-20010

Pivot pins and retainers are supplied with Rod Clevises.

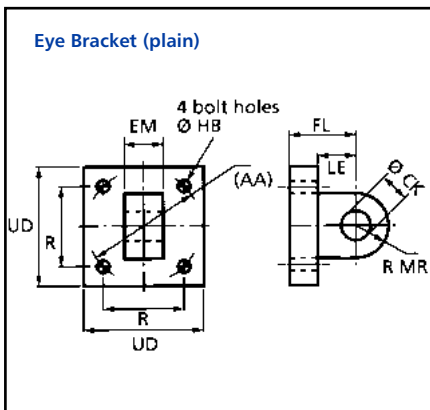

Plain Eye Bracket									
Part Number	CK _{h9}	EM _{h13}	FL	MR Max.	LE Min.	AA	HB	R	UD
MBP-20001	10	12	23	12	13	40	5.5	28.3	38
MBP-20002	12	16	29	17	19	47	6.6	33.2	45
MBP-20003	14	20	29	17	19	59	9	41.7	64
MBP-20004	20	30	48	29	32	74	13.5	52.3	76
MBP-20005	20	30	48	29	32	91	13.5	64.3	89
MBP-20006	28	40	59	34	39	117	17.5	82.7	115
MBP-20007	36	50	79	50	54	137	17.5	96.9	127
MBP-20008	45	60	87	53	57	178	26	125.9	165
MBP-20009	56	70	103	59	63	219	30	154.9	204
MBP-20010	70	80	132	78	82	269	33	190.2	240

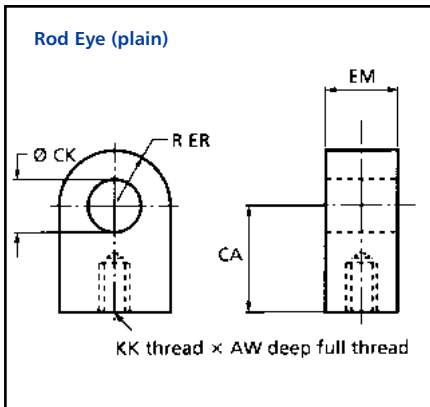

Plain Rod Eye							
Part Number	AW	CA	CK	EM	ER Max.	KK	Matching Clevis Mtg Bracket
REF-24001	14	32	10	12	12	M10 X 1.25	MBC-21001
REF-24002	16	36	12	16	17	M12 X 1.25	MBC-21002
REF-24003	18	38	14	20	17	M14 X 1.5	MBC-21003
REF-24004	22	54	20	30	29	M16 X 1.5	MBC-21004
REF-24005	28	60	20	30	29	M20 X 1.5	MBC-21005
REF-24006	36	75	28	40	34	M27 X 2	MBC-21006
REF-24007	45	99	36	50	50	M33 X 2	MBC-21007
REF-24008	56	113	45	60	53	M42 X 2	MBC-21008
REF-24009	63	126	56	70	59	M48 X 2	MBC-21009
REF-24010	85	168	70	80	78	M64 X 3	MBC-21010

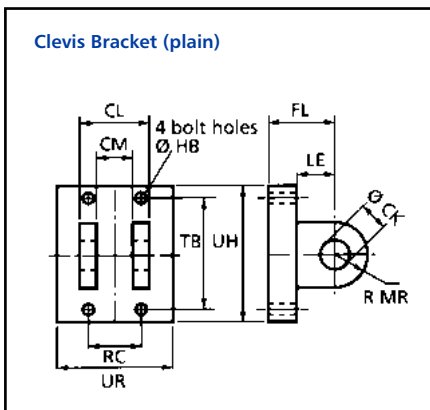

Clevis Bracket (plain)											
Part Number	CK _{h9}	CL	CM	FL	HB	LE Min.	MR Max.	RC	TB	UH	UR
MBC-21001	10	26	12	23	5.5	13	12	18	47	60	38
MBC-21002	12	34	16	29	6.6	19	17	24	57	70	45
MBC-21003	14	42	20	29	9	19	17	30	68	85	60
MBC-21004	20	62	30	48	13.5	32	29	45	102	125	77
MBC-21006	28	83	40	59	17.5	39	34	60	135	170	100
MBC-21007	36	103	50	79	17.5	54	50	75	167	200	127
MBC-21008	45	123	60	87	26	57	53	90	183	230	150
MBC-21009	56	143	70	103	30	63	59	105	242	300	180
MBC-21010	70	163	80	132	33	82	78	120	300	360	200

Pivot pins and retainers are supplied with Clevis Brackets.

MOUNTING ACCESSORIES

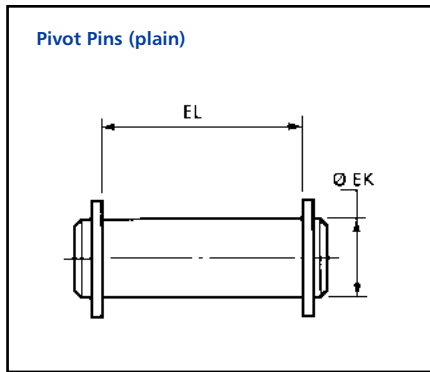

Pivot Pin (plain)					
Part Number	EK _ø	EL Min.	Axial Nominal Load Capacity	To Match Rod Clevis	To Match Clevis Bracket
PPC-18141	10	29	8kN	CLS-23001	MBC-21001
PPC-18142	12	37	12.5	CLS-23002	MBC-21002
PPC-18143	14	45	20	CLS-23003	MBC-21003
PPC-18144	20	66	50	CLS-23004/5	MBC-21004
PPC-18146	28	87	80	CLS-23006	MBC-21006
PPC-18147	36	107	125	CLS-23007	MBC-21007
PPC-18148	45	129	200	CLS-23008	MBC-21008
PPC-18149	56	149	320	CLS-23009	MBC-21009
PPC-18150	70	169	500	CLS-23010	MBC-21010

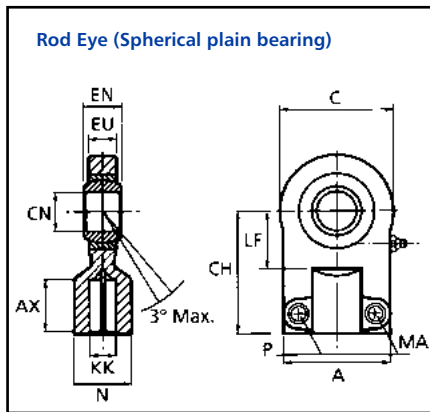

Rod Eye (Spherical plain Bearing)												
Part Number	A Max.	AX Min.	C	CH	CN	EN	EU	KK	LF	MA* Max.	N Max.	P
REB-12DO	40	15	32	42	12 ⁺⁰ _{-0.008}	10	8	M10 X 1.25	18	9.5	17	M6
REB-16DO	45	17	42	48	16 ⁺⁰ _{-0.008}	14	11	M12 X 1.25	22	9.5	21	M6
REB-20DO	55	19	50	58	20 ⁺⁰ _{-0.012}	16	13	M14 X 1.5	28	23	25	M8
REB-25DO	62	23	62	68	25 ⁺⁰ _{-0.012}	20	17	M16 X 1.5	34	23	30	M8
REB-30DO	80	29	76	85	30 ⁺⁰ _{-0.012}	22	19	M20 X 1.5	38	46	36	M10
REB-40DO	90	37	96	105	40 ⁺⁰ _{-0.012}	28	23	M27 X 2	48	46	45	M10
REB-50DO	105	46	116	130	50 ⁺⁰ _{-0.012}	35	30	M33 X 2	62	80	55	M12
REB-60DO	134	57	150	150	60 ⁺⁰ _{-0.015}	44	38	M42 X 2	74	195	68	M16
REB-80DO	156	64	195	185	80 ⁺⁰ _{-0.015}	55	47	M48 X 2	98	385	78	M20
REB-100DO	190	86	235	240	100 ⁺⁰ _{-0.020}	70	57	M64 X 3	122	660	100	M24

*Tightening bolts torque value (Nm).

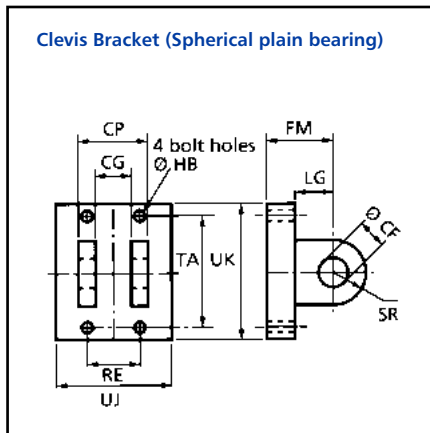

Clevis Bracket (Spherical plain Bearing)												
Part Number	CF _{k7}	CG _{A16}	CP Max.	FM	HB	LG Min.	RE	SR Max.	TA	UJ Max.	UK Max.	Nominal Load Capacity
MBB-22001	10	11	25	33	5.5	23	17	9.5	59	45	80	8kN
MBB-22002	12	12	30	36	6.6	26	20	11	65	50	85	8kN
MBB-22003	16	16	38	42	9	32	25	13	84	60	110	12.5
MBB-22004	20	18	50	51	13.5	35	33	18	106	85	140	20
MBB-22005	25	22	54	64	13.5	48	37	23	130	85	165	32
MBB-22006	30	24	67	72	17.5	52	44	30	137	110	175	50
MBB-22007	40	30	83	104	17.5	79	55	39	191	135	235	80
MBB-22008	50	38	101	123	26	93	68	45	234	165	295	125
MBB-22009	60	47	120	144	30	104	82	57	288	190	355	200
MBB-22010	80	58	141	182	33	133	98	76	366	225	445	320
MBB-22011	100	73	174	220	33	140	98	100	366	225	445	500

Pivot pins and retainers are supplied with Clevis Brackets.

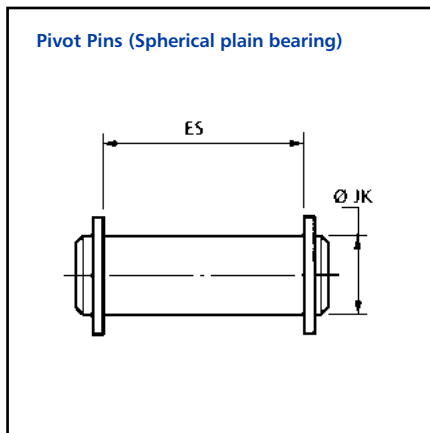

Pivot Pin (Spherical Bearing)				
Part Number	JK _ø	ES Min.	Axial Nominal Load Capacity	To Match Clevis Bracket
PPB-22041	10	26	8kN	MBB-22001
PPB-22042	12	31	8kN	MBB-22002
PPB-22043	16	39	12.5	MBB-22003
PPB-22044	20	51	20	MBB-22004
PPB-22045	25	55	32	MBB-22005
PPB-22046	30	68	50	MBB-22006
PPB-22047	40	84	80	MBB-22007
PPB-22048	50	102	125	MBB-22008
PPB-22049	60	121	200	MBB-22009
PPB-22050	80	142	320	MBB-22010
PPB-22051	100	175	500	MBB-22011

Spherical Bearings Application Limitations

The bearings fitted to the accessories listed above are sized such that adequate bearing life can be expected under normal operating conditions. However, as the service life of a spherical bearing is affected by a number of factors, these must be taken into consideration when severe or unusual working conditions prevail.

Factors to be considered

1. Type of load - alternating, pulsating, shock.
2. Direction of load.
3. Degree of movement - swivel angle, sliding velocity, tilt angle, swivel frequency.
4. Temperature
5. Maintenance interval (lubrication)
6. Environmental conditions - contamination, erosion.

		Theoretical Force in Newtons at Various Pressures (in bars)																							
Bore	Rod	Effective Area Push sq.mm	Effective Area Pull sq.mm	7 Bar		17 bar		35 bar		52 bar		70 bar		103 bar		138 bar		207 bar							
				Push	Pull	Push	Pull	Push	Pull	Push	Pull	Push	Pull	Push	Pull	Push	Pull	Push	Pull	Push	Pull				
25	12	491	378	344	265	835	643	1719	1323	2553	1966	3437	2646	5057	3893	6776	5216	10164	7825						
	18	491	336	344	165	835	401	1719	826	2553	1227	3437	1652	5057	2431	6776	3257	10164	4885						
32	14	804	650	563	455	1367	1105	2814	2275	4181	3380	5628	4550	8281	6695	11095	8970	16643	13455						
	22	804	424	563	297	1367	721	2814	1484	4181	2205	5628	2968	8281	4367	11095	5851	16643	8777						
40	18	1257	1002	880	701	2137	1703	4400	3507	6536	5210	8799	7014	12947	10321	17347	13828	26020	20741						
	28	1257	641	880	449	2137	1090	4400	2244	6536	3333	8799	4487	12947	6602	17347	8846	26020	13269						
50	22	1964	1584	1375	1109	3339	2693	6874	5544	10213	8237	13748	11088	20229	16315	27103	21859	40655	32789						
	28	1964	1348	1375	944	3339	2292	6874	4718	10213	7197	13748	9436	20229	13884	27103	18602	40655	27904						
63	36	1964	946	1375	662	3339	1608	6874	3311	10213	4919	13748	6622	20229	9744	27103	13055	40655	19582						
	28	3117	2501	2182	1751	5299	4252	10910	8754	16208	13005	21819	17507	32105	25760	43015	34514	64522	51771						
80	36	3117	2100	2182	1470	5299	3570	10910	7350	16208	10920	21819	14700	32105	21630	43015	28980	64522	43470						
	45	3117	1526	2182	1068	5299	2594	10910	5341	16208	7935	21819	10682	32105	15718	43015	21059	64522	31589						
100	36	5027	4009	3519	2806	8546	6815	17595	14032	26140	20847	35189	28063	51778	41293	69373	55324	104059	82986						
	45	5027	3436	3519	2406	8546	5842	17595	12026	26140	17867	35189	24052	51778	35391	69373	47417	104059	71125						
125	56	5027	2564	3519	1795	8546	4359	17595	8974	26140	13333	35189	17948	51778	26409	69373	35383	104059	53075						
	45	7854	6263	5498	4384	13352	10647	27489	21921	40841	32568	54978	43841	80896	64509	108585	86429	162578	129644						
160	56	7854	5391	5498	3774	13352	9165	27489	18869	40841	28033	54978	37737	80896	55527	108585	74396	162578	111594						
	70	7854	4005	5498	2804	13352	6809	27489	14018	40841	20826	54978	28035	80896	41252	108585	55269	162578	82904						
200	56	12272	9809	8590	6866	20862	16675	42952	34332	63814	51007	85904	68663	126402	101033	169354	135364	254030	203046						
	70	12272	8423	8590	5897	20862	14320	42952	29481	63814	43800	85904	58961	126402	86757	169354	116237	254030	174356						
200	90	12272	5910	8590	4137	20862	10047	42952	20685	63814	30732	85904	41370	126402	60873	169354	81558	254030	122337						
	70	20106	16257	14074	11380	34180	27637	70371	56900	104551	84536	140742	113799	207092	167447	277463	224347	416194	336520						
200	90	20106	13743	14074	9622	34180	23365	70371	48100	104551	71464	140742	96201	207092	141553	277463	189653	416194	284480						
	110	20106	10603	14074	7422	34180	18025	70371	37111	104551	55136	140742	74221	207092	109211	277463	146321	416194	219482						
200	90	31416	25054	21991	17538	53407	42592	109956	87689	163363	130281	219912	175378	323585	258056	433541	345745	650311	518618						
	110	31416	21911	21991	15341	53407	37251	109956	76689	163363	113937	219912	153377	323585	225683	433541	302372	650311	453556						
140	31416	16022	21991	11215	53407	27237	109956	56077	163363	83314	219912	112154	323585	165027	433541	221104	650311	331655							

THEORETICAL FORCES DEVELOPED BY CYLINDERS

Force Developed on Push Stroke

$$F = \frac{AP}{10}$$

Force (Newtons) = Area of Piston (in sq. mm) times Pressure (in bar) divided by 10

Force Developed on Pull Stroke

$$F = \frac{(A_p - A_r) P}{10}$$

Force (Newtons) = Area of Piston (in sq. mm) less Area of Rod (in sq. mm) times Pressure (in bar) divided by 10

Speed of Cylinder Travel

$$S = \frac{Q \times 10^3}{A}$$

S = Speed in metres per minute
 Q = Pump delivery in litres per minute
 A = Area of Piston in square mm - Rod Extend
 or
 A = Area of Piston minus Area of Rod - Rod Retract

CUSHIONS

Cushions

Tapered cushions, designed to provide gradual deceleration and eliminate shock upon entrance of the cushion pistons, have now been considerably improved. The tapered cushion has been married with a fine thread, wide range, adjusting screw. This new combination offers a positive, lowshock deceleration and a method to adjust the cushioning effect for speeds and loads.

Cushion Lengths			
Bore	Rod	Cushion Length	
		Head	Cap
25	All	16	15
32	All	16	15
40	All	22	22
50	All	22	22
63	All	22	22
80	36	22	25
	45	22	25
	56	25	25
100	45	22	25
	56	25	25
	70	25	25
125	56	25	25
	70	25	25
	90	25	25
160	70	25	28
	90	25	28
	110	30	28
200	90	25	38
	110	30	38
	140	30	38

The adjusting screw is identified by a crossslot in the head of the screw. It does not project beyond the surface of the head (or cap) through its full range of adjustment so no clearance need be considered on close fit installations. The adjusting screw and the cushion check can be interchanged in the same cylinder end. This flexibility can be important if, after installation, it is discovered that the adjusting screw is inaccessible.

The cushion check, which does not require adjustment, has a single slot in its head. It does not project beyond the surface of the head (or cap). The cushion check plus the tapered cushion piston provides rapid acceleration out of cushioning. There is no spring in the cushion check to fatigue, hence, no worry of mechanical failure.

All cushion screws are held captive by a spring-loaded retaining ring. This ring is removable for maintenance or changeover purposes.

Cushioning is designed to properly cushion the cylinder and is not intended to cushion large inertia loads. Cushions do not substitute for speed controls or deceleration valves on most installations.

As indicated the standard positions for ports are 1 and 5. Where possible, the standard for cushion adjusting screws will be 2 and 6 and the standard positions for cushion checks will be 4 and 8. With some mounting styles, it is not possible to so locate the adjusting screws and checks. For example, a Trunnion Front Mount has the trunnion pins located in positions 2 and 4 on the head. With the port in position 1, the only side available for *both* adjusting screw and check is position 3. Since both will then be located on the same side, they will be located off-centre. This example would hold true with the TR, CL, FHF and RHF Mounts. See Chart A for standard positions that will be supplied unless otherwise specified. When requested, other positions can be supplied so long as there is no interference with mounting.

Where access to an adjusting Screw or check could be made difficult because of proximity to a mount, the locations of the screws will be slightly off-centre. An example of this would be a small bore cylinder with a side lug mount.

Because of space limitations, neither cushion adjusting screws nor cushion ball checks can be put into 25 and 32 bore sizes. Nor can they be put into 40 and 50 bore sizes for cushioned front when they are specified with 2:1 rod diameters.

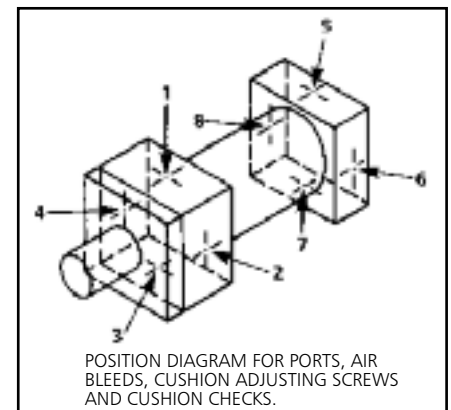

Chart A		
Mount	Cush. Adj Screw	Cush Check
TF and FHF	3 and 6	3 and 8
TR and RHF	2 and 7	4 and 7
All Other Mounts	2 and 6	4 and 8

Standard Positions for Cushion Adjusting Screws and Cushion Checks in Relation to Port Positions by Style of Mounting. For information concerning cushion lengths - please consult factory.

◆ MOUNTING INFORMATION

Fixed Centreline Mounts

Centreline mounts are generally considered to be the best type of fixed mounting since the thrust from the piston rod is taken at a mounting surface that is coincident with the cylinder centreline. Use of this type of mount can eliminate possible problems resulting from cylinder sway and flexure of cylinder components.

Flange Mounts

The type of flange recommended for backside mounting is the style where the full thickness of the head or the cap serves as the flange (Styles FHF or RHF). Selection of a flange mounting style depends, in part, upon whether the major force applied to the machine member will result in tension or compression of the cylinder rod. Rear flange mounting styles are best for thrust loads (rod in compression) and front flange mounting styles are best where the rod is stressed in tension.

Regardless of mount, whenever a long stroke cylinder is employed, consideration should be given to additional support - see page 13 for long stroke cylinder data.

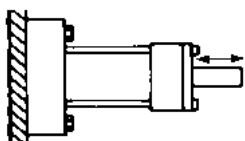

Rear Head Flange Style RHF

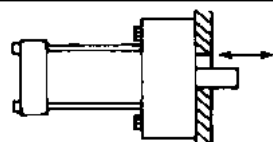

Front Head Flange Style FHF

Flange styles of mounting are dimensioned on pages 16 and 17.

Tie Rod Extended Mounts

Tie Rod Extended cylinders are available with the tie rods extended front (Style FX), with the tie rods extended rear (Style RX) or both ends (Style BX). Frequently cylinders are ordered with tie rods extended on one end in addition to another mount. The extended tie rods are then utilised for the mounting of other systems or machine components.

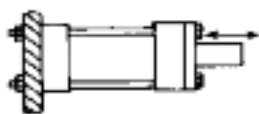

Tie Rod Extended Styles FX, RX & BX

Tie Rod Extended Mounts Cont.

Should the mounting be such that the overhung weight of the cylinder is borne by the extended tie rods, additional support may be required, especially if the cylinder has a long stroke (see page 13). From a thrust standpoint, tie rod extended mounts are good, stable ones. Dimensions for tie rod extended mounts are shown on pages 22 and 23.

Pivoted Centreline Mounts

If the machine member moved by the piston rod travels in a curvilinear path, a pivot mount cylinder is the obvious choice. Pivotal mounts are available with the pivot points at the head (TF Mount), at the cap (TR, P & C Mounts), or centrally located at some position between the head and the cap (T Mount). In most cases, a layout of the rod end path will determine the best pivot mounting style to be used. In general, pivot mounted cylinders with the pivot points near the head (TF and T Mounts) can use smaller diameter rods without the danger of buckling than similar cylinders with the pivot points at the cap. This can be verified by consulting our column strength chart on page 15.

There are times when a fixed mounting style might be indicated by an application but a pivot mount is selected to compensate for any misalignment that might occur - if the misalignment is in one plane. Where misalignment can occur in multiple planes, the cylinder should be equipped with Spherical Bearings (see page 20).

Trunnion Mounts

Pillow blocks of ample size and rigidity should be provided and should be mounted as close to the head (or cap) as possible. Bearing should be provided for the full length of the trunnion pin. Pins are intended for shear loads only, not bending loads. SELF-ALIGNING MOUNTS should NOT BE USED TO SUPPORT THE TRUNNIONS SINCE BENDING FORCES CAN ALSO BE SET UP (See Fig. C). Lubrication should be provided to the pins.

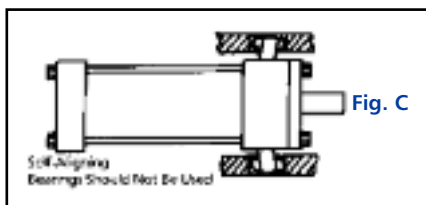

An intermediate trunnion (T Mount) can be located at any position between the head and cap (within limitations) at the time of cylinder manufacture, but cannot be easily changed once produced. The trunnion location (dimension XI) must be specified on the order. See pages 18 and 19 for trunnion mount dimensions.

Clevis Mount

All Clevis Mount cylinders need provision on both ends for pivoting in one direction. A clevis pin of proper length and of sufficient diameter to withstand the maximum shear load generated by the cylinder at rated operating pressure is provided. Should a rod end accessory such as a rod eye or rod clevis (see pages 6 and 7) be desired, select one with a pin size (or pin hole) with the same diameter as the clevis pin. You can then specify a rod end thread to match the accessory.

Selecting the accessory on the basis of the rod end thread normally supplied can result in an expensive and unsightly mismatch, especially when the cylinder has a large oversize or 2:1 diameter rod. Clevis mount cylinder dimensions are given on pages 20 and 21.

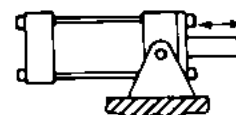

Trunnion Front Style TF

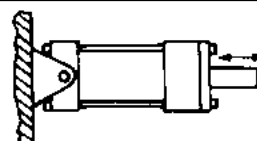

Trunnion Rear Style TR

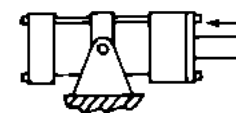

Intermediate Trunnion Style T

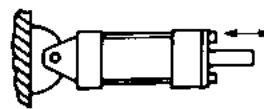

Clevis Style C

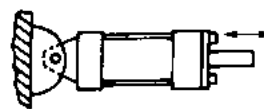

Pivot Style P

◆ MOUNTING INFORMATION

Fixed Non-Centreline Mounts

Cylinders with non-centrelines styles of mounts tend to sway when under load. Relatively short fixed, non-centrelines mounted cylinders can subject mounting bolts to large tension forces which, when combined with shear forces, can overstress standard bolts. High tensile cap screws are recommended. See Fig. D.

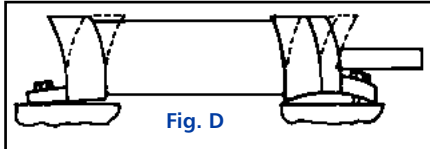

The rigidity of the machine frame should be considered when using cylinders with a non-centrelines mount since stronger machine members are often required to resist bending moments. See Fig. E.

Fixed mounted cylinders should be held in place by keying or pinning. Cylinders with integral key mounts may be used where a keyway can be milled in a machine member (see page 12). This type of arrangement takes up shear loads and provides accurate alignment of the cylinder. Shear keys should be placed at the proper end of the cylinder: at the head, if major loads are in thrust or at the cap if major loads are in tension. See Fig. F.

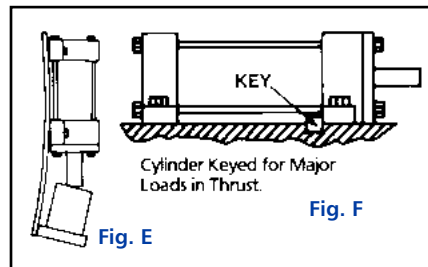

Only one end of the cylinder should be keyed. Dowel pins can be used instead of keys to help take shear loads and to obtain alignment. The side lug mount has room for dowel pins in the lugs. Cylinders may be pinned together at either end but NOT AT BOTH ENDS.

Dimensions for SL Mounts are given on pages 16 and 17.

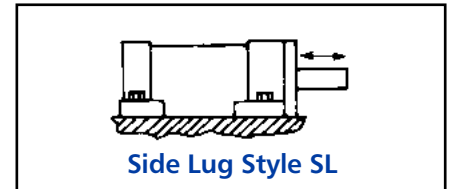

◆ PORTING AND AIR BLEEDS

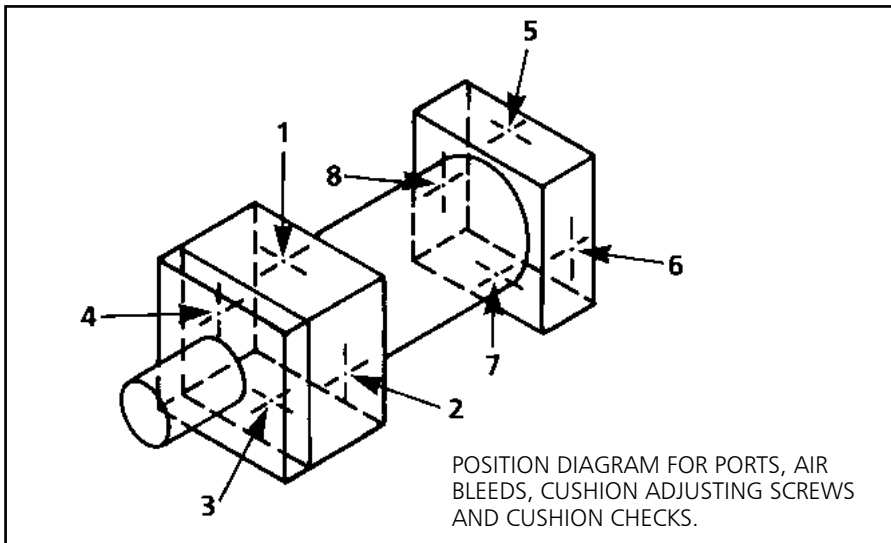

Porting

BSP Ports, located in positions 1 and 5 (See "Position Diagram for Ports") are standard options and will be furnished as specified.

Port Positions

Where mounting clearances permit, the ports can be had in any of four positions in the head and in the cap at no extra cost. Indicate both port positions desired by position number. If no preference is stated, ports will be furnished in positions 1 and 5. NOTE: The head and cap can be rotated in relation to each other as long as mounting and porting are convenient for installation.

Air Bleeds

An air bleed may be ordered at either or both ends of the cylinder as an option. To provide for maximum bleeding of air from the cylinder, air bleeds are placed in the tube to bleed air from the tube/head or tube/cap juncture. The air is bled from the cylinder by backing out the straight thread metallic seal plug to allow air to pass by the threads. When air bubbles stop and oil starts to flow, re-tighten plug. It is recommended that bleeding be done with pressure on the opposite end of the cylinder so that the bleed plug is not subjected to pump pressure when being backed out. Air bleeds should always be positioned at the highest point of the cylinder tube. Please specify positions of air bleeds by position number from the chart. NOTE: Since air bleeds are placed in the cylinder tube, position can be changed by loosening the tie rods and rotating the tube. Line drawing shows ports in positions 1 and 5.

◆ PRESSURE

Pressure and Shock

EH Series Cylinders are suitable for working pressures to 210 bar with a 3:1 safety factor based on yield and maximum pressure including any shock to 345 bar. See page 31 for complete line of Cylinders for pressures to 550 bar.

The following factors in shock loading should be considered:

- n Relief valves in the circuit do not protect the components from shock because of the time lag.
- n Gauges do not necessarily register shock conditions, either because of their position in the circuit, or the short duration of shock.
- n The two general types of shock loading to be considered are pressure rise caused by quick stop of the flow in the circuit and quick pressure drop. Decompression shock is particularly important in large bore cylinders and can be as destructive as compression shock.
- n The magnitude of the pressure difference and the duration that the maximum pressure exists are the factors that determine the damage from shock.

Many cylinders are manufactured with variations to meet special customer needs. In addition to those illustrated below, some of the more popular variations are:

- n Cylinders With Gaiters
- n Combination Mount Cylinders
- n Locking Cylinders
- n Precision Stroke Cylinders
- n Precision Mount Cylinders
- n Cylinders With Built-In Switch Actuators & Feed Back Devices

Thrust Key

All side mounted cylinders (SL Mount) can be supplied with thrust keys. Thrust keys are available in bore sizes 25 through 200. Extending the rod gland retainer, as shown, provides a key which fits into a milled slot in the mounting surface of the machine member. Combined with the mount this key assures that the cylinder will not shift in severe service.

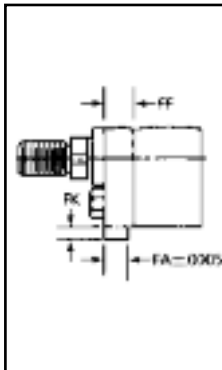

Bore	FA	FF	FK
25	8	10	5
32	8	10	5
40	8	10	5
50	14	16	8
63	14	16	8
80	18	20	10
100	22	22	11
125	22	-	11
160	24	-	13
200	24	-	13

Spherical Bearings

Clevis mounting brackets and pivot rod eyes can be provided with spherical bearings to compensate for misalignment on both ends of cylinders.

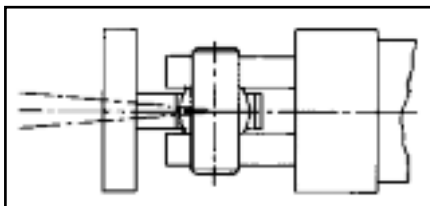

Adjustable Stroke

Shown is an integral stroke adjustment (externally adjusted) that is accomplished by the use of a bump rod threaded into the cylinder cap. Seals are incorporated to prevent external leakage and a lock nut is included.

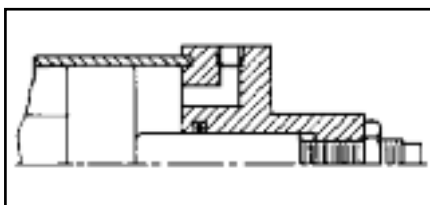

Non-Rotating Piston Rod

Two methods of non-rotating piston rods are employed. The internal rod type (Fig. A.) is generally used since it requires less space and is neater. The type shown in Fig. B. must be used on small bore cylinders where internal space is limited.

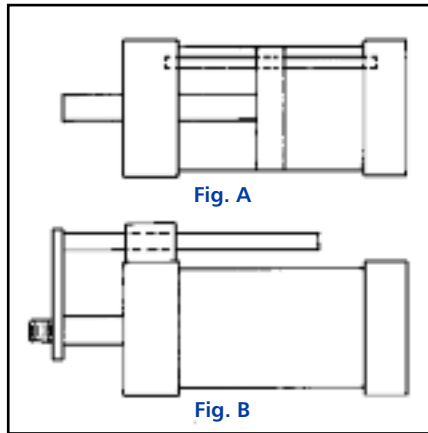

Rod Gland Drain Back

When not even a drop of external leakage can be tolerated, the rod gland drain back provides a signal that the rod seal set has worn to the point of replacement - without the danger of contamination from leakage.

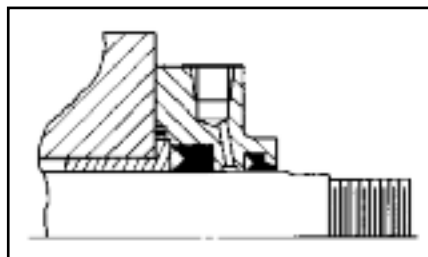

Tandem Cylinders and Multi-Stage Cylinders

The tandem cylinder (Fig. A.) has two pistons connected to a common rod, resulting in twice the force output of a single cylinder. Multi-stage cylinders (Fig. B) offer multiple, positive strokes by pressurising one cylinder, the other, or both. Contact the factory for other variations.

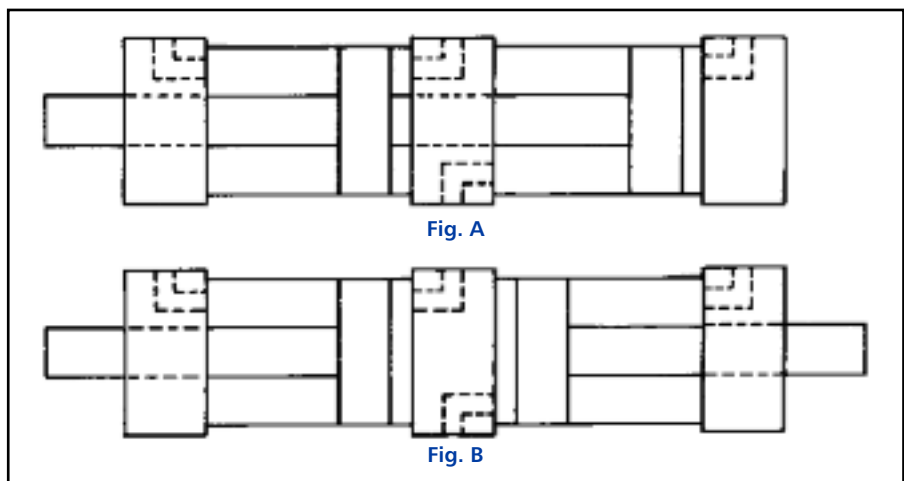

Vacuum Rod Seal

When a cylinder is to be operated under water, provision is made to prevent the water from being drawn into the cylinder at the time of valve shift or pressure differential.

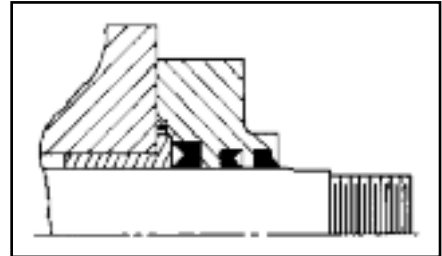

Stainless Steel Piston Rods

Many applications, especially those subjected to water spray, require the use of stainless steel piston rods. We stock 431-S29T hard chrome plated, stainless steel and will furnish that type unless otherwise specified. Other types of stainless steel can be provided on request.

PLEASE REQUEST A QUOTATION FOR ANY SPECIAL CYLINDER REQUIREMENTS. SEE PAGES 4 AND 5 FOR INFORMATION CONCERNING HIGH TEMPERATURE AND WATER HYDRAULIC CYLINDERS

LONG STROKE CYLINDERS

Stroke Limitations

There are several considerations that may fix the *Practical* stroke limit of a cylinder such as mounting style, mounting attitude, column strength of the piston rod, etc. These will be discussed later in this section. There are, however, *Definite* stroke limitations imposed by the basic design of tie rod cylinders. Because of the tube loading required to properly prestress (torque) tie rods, the following bore size cylinders are limited to the corresponding strokes in standard, catalogued construction. Should you require a cylinder with a stroke in excess of that charted below, contact the factory for information concerning changes in construction and dimensions.

Bore Size	Maximum Stroke
25 & 32	750
40	1400
50	2600
63	3200
80 and larger	4300

Supports

Relatively long cylinders often require supports to prevent excessive sag or vibration which could severely reduce the operational life of the cylinder. Depending upon bore size and mounting style, it may be necessary to specify either an intermediate mount or a tie rod support bracket. If the cylinder selected has a fixed, non-centreline mount such as side lug, the type of support to select should be an intermediate mount (see Fig. 1). This additional mount provides support for the cylinder tube *and* support for the tie rods. If a pivotal mount such as clevis or trunnion is selected, a tie rod support bracket should be considered (see Fig. 2). When a long stroke cylinder, with a fixed centreline mount such as a front or rear flange is specified, some form of support should be provided. An intermediate mount is often the most convenient way of doing so (see Fig. 3). The following chart provides a guide for determining the need for an additional support. It should be noted that neither a tie rod support bracket nor an intermediate mount is designed to absorb the thrust of the cylinder. They provide support only.

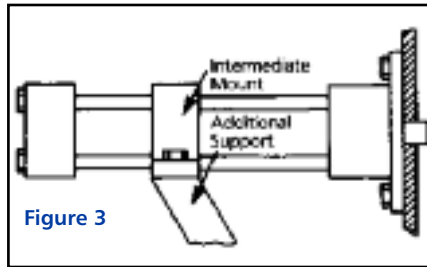
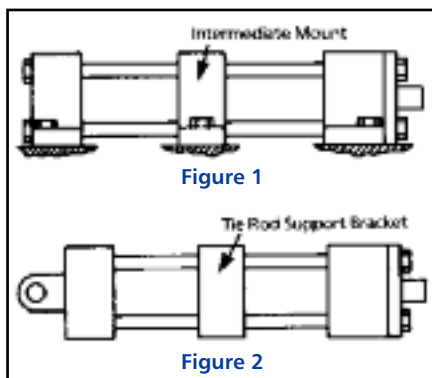

Figure 3

Bore	Stroke Requiring additional support
50	2100
63	2100
80	2500
100	2500
125	3000
160	3400
200	3700

Rod Column Strength

When considering a long stroke cylinder, it is necessary to select a piston rod size of sufficient diameter to provide the necessary column strength. If the cylinder will be performing work on the pull stroke only (rod in tension), selection of the standard rod diameter for that bore size will provide sufficient strength for operation at rated pressure or lower. If, however, the cylinder will be performing work on the push stroke (rod in compression), careful consideration must be given to column strength. Factors are the stroke length, rod extension length, mounting style, mounting attitude, force potential and rod end connection. This is simplified for you by using the charts on **pages 14 and 15**. The mounting class chart on **page 14** assigns a mounting class reference number that corresponds to the mounting style, mounting attitude and rod end connection of the cylinder selected. Referencing that number and the sum of the gross stroke plus rod extension (if any), the column strength chart on **page 15** indicates the maximum allowable force for each available rod diameter. You may find the theoretical force chart on **page 8** helpful in calculating the force requirements.

Stop Tube and Dual Piston

A stop tube is a tube or sleeve assembled in the cylinder between the head and the piston. It provides a spread between the bearings of the rod bushing and the piston when the rod is fully extended (see Fig. 4). The use of a stop tube is an accepted method for reducing bearing pressures on long stroke cylinders and cylinders subjected to excessive side loading. A stop tube does not afford *additional* bearing surface, nor does it provide any benefit during operation except at full extension of effective stroke. While we will equip cylinders with stop tubes, our strong recommendation is for an alternate and superior method for reducing bearing pressures - the dual piston.

The dual piston is an assembly of two pistons on the piston rod. They are separated by a spacer of calculated length. Both pistons are equipped with bearing strips thus avoiding the metal to metal contact that causes most operational problems with competitive cylinders when subjected to side loading (see Fig. 5). The dual piston not only provides bearing spread at all times throughout the stroke cycle, but also provides important additional bearing surface. The dual piston concept was originally developed to successfully solve the most severe side loading problems when other methods had failed.

Both dual piston and stop tube equipped cylinders will be longer by the length of the stop tube or dual piston than standard cylinders of the same stroke without those devices. The desired stroke (effective stroke) must be added to the length of stop tube or dual piston to obtain the gross stroke for determining cylinder dimensions. Since the dual piston offers much greater effectiveness than a stop tube, it is usually shorter than the corresponding stop tube, hence the total cylinder length will be less; frequently a most important factor in total machine design.

To determine the length of stop tube or dual piston required, first consult the mounting class chart on **page 14** to obtain a Mounting Class Reference Number. Referencing that number and the net stroke of the cylinder, the required stop tube or dual piston length can be obtained from the chart on **page 14**.

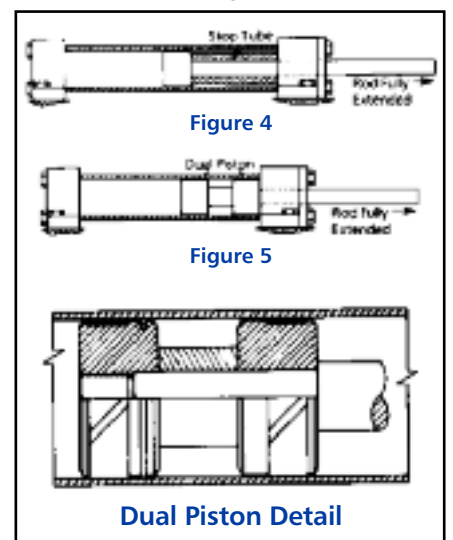
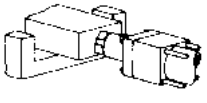
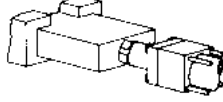
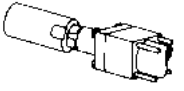
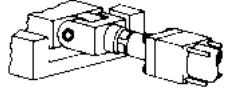
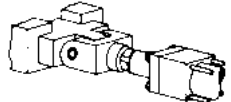

Figure 4

Figure 5

Dual Piston Detail

MOUNTING CLASSES

Type of Cylinder Rod End Connection		
	Fixed, Supported, and Unguided	Type A
	Fixed, Supported, and Guided	Type B
	Free, Unsupported, and Unguided	Type C
	Pivoted, Supported, and Unguided	Type D
	Pivoted, Supported, and Guided	Type E

Determine the type of rod end connection to be made. Then, using the charts below, reference that connection type to the Mounting Style of the cylinder. The resulting class number is employed as a factor in determining Stop Tube, Dual Piston, and Column Strength.

Mounting Style		
	Type	Class
Flange Mounts (FHF, RHF)	B	1
Lug Mounts (SL)	E	2
Tie Rod Extended Mounts (FX, RX, BX)	A, D	3
	C	6
Trunnion Front Mount (TF)	D, E	3
Intermediate Trunnion Mount (T)	D, E	4
Trunnion Rear Mount (TR)	D, E	5
Clevis Mount (C)		
Pivot Mount (P)		
Spherical Bearing (SBp)	D, E	6

STOP TUBE AND DUAL PISTON

Net Stroke	Class 1		Class 2		Class 3		Class 4		Class 5		Class 6		
	Stop Tube	Dual Piston	Stop Tube	Dual Piston	Stop Tube	Dual Piston	Stop Tube	Dual Piston	Stop Tube	Dual Piston	Stop Tube	Dual Piston	
400											25	m	
500											50	m	
600											75	m	
630										25	m	75	m
660										25	m	100	m
700										50	m	100	m
800										50	m	125	75
850								25	m	75	m	150	100
900								25	m	75	m	175	125
950								50	m	75	m	175	125
1050								50	m	100	m	200	125
1100								50	m	125	75	225	150
1150					25	m	75	m	125	75	250	175	
1200					25	m	75	m	150	100	250	175	
1300					25	m	100	m	150	100	275	175	
1350					25	m	100	m	175	125	300	200	
1400					50	m	100	m	175	125	325	225	
1450					50	m	125	75	200	125	325	225	
1550					50	m	125	75	200	125	350	225	
1600			25	m	50	m	150	100	225	150	375	250	
1700			25	m	75	m	150	100	225	150	400	275	
1800			25	m	75	m	175	125	250	175	425	275	
1900			50	m	75	m	175	125	275	175	450	300	
2000			50	m	100	m	175	125	275	175	475	325	
2100			50	m	100	m	200	125	300	200	500	325	
2150			50	m	100	m	200	125	325	225	525	350	
2250			75	m	125	75	225	150	325	225	550	375	
2300			75	m	125	75	225	150	350	225	575	375	
2350			75	m	125	75	250	175	350	225	575	375	
2400	25	m	75	m	125	75	250	175	375	250	600	400	
2500	25	m	75	m	150	100	275	175	375	250	625	425	
2550	25	m	100	m	150	100	275	175	400	275	650	425	
2600	25	m	100	m	150	100	275	175	400	275	650	425	
2650	25	m	100	m	150	100	300	200	425	275	675	450	
2750	25	m	100	m	175	125	300	200	450	300	700	475	
2800	25	m	100	m	175	125	300	200	450	300	725	475	
2850	50	m	100	m	175	125	325	225	450	300	750	500	
2900	50	m	125	75	175	125	325	225	475	325	750	500	
2950	50	m	125	75	200	125	325	225	475	325	775	525	
3000	50	m	125	75	200	125	350	225	500	325	775	525	
3050	50	m	125	75	200	125	350	225	500	325	800	525	
3200	50	m	125	75	225	150	375	250	525	350	850	575	
3300	75	m	150	100	225	150	400	275	550	375	875	575	
3400	75	m	150	100	250	175	400	275	575	375	925	625	

m Dual piston not available – use Stop Tube.

COLUMN STRENGTH CHART

Maximum Allowable Force in Newtons (Compressive Load)													
Stroke Plus Rod Ext.	Mount Class	Piston Rod Diameter											
		12	14	18	22	28	36	45	56	70	90	110	140
250	1	22182	31568	54673	83553	137704	230122	361709	562248	880656	1458266	1091101	2121364
	2	17420	26806	49910	78791	132942	225359	356946	557485	875893	1453503	1089910	2119649
	3	11082	20138	43242	72123	126274	218692	350278	550818	869225	1446836	1088243	2117249
	4	4926	9125	24935	53072	107223	199641	331228	531767	850175	1427783	1083481	2110391
	5	2771	5133	14026	31300	80552	172970	304557	505096	823504	1401114	1076813	2100789
	6	1231	2281	6234	13911	36500	99741	228354	428893	747301	1324911	1057762	2073355
375	1	17420	26806	49910	78791	132942	225359	356946	557483	875893	1453503	1089910	2119649
	2	8756	16222	39194	68075	122226	214643	346230	546769	865177	1442787	1087231	2115792
	3	4926	9125	24935	53072	107223	199641	331228	531767	850175	1427785	1083481	2110391
	4	2189	4056	11082	24731	64890	156777	288364	488903	807310	1384921	1072765	2094959
	5	1231	2281	6234	13911	36500	99741	228354	428893	747301	1324911	1057762	2073355
	6	547	1014	2771	6183	16222	44330	108226	259558	575844	1153454	1014897	2011630
500	1	11082	20138	43242	72123	126274	218692	350278	550818	869225	1446836	1088243	2117249
	2	4926	9125	24935	53072	107223	199641	331228	531767	850175	1427785	1083481	2110391
	3	2771	5133	14026	31300	80552	172970	304557	505096	823504	1401114	1076813	2100789
	4	1231	2281	6234	13911	36500	99741	228354	428893	747301	1324911	1057762	2073355
	5	693	1283	3507	7825	20531	56105	136974	322209	640616	1218227	1031090	2034948
	6	308	570	1558	3478	9125	24935	60877	146002	356449	913415	954886	1925214
625	1	7093	13140	34670	63550	117701	210119	341706	542245	860652	1438263	1086100	2114163
	2	3152	5840	15959	35812	87934	180352	311939	512478	830886	1408496	1078658	2103447
	3	1773	3285	8977	20032	52561	138678	270265	470804	789212	1366823	1068240	2088444
	4	788	1460	3990	8903	23360	63835	155846	351737	670145	1247755	1038473	2045579
	5	443	821	2244	5008	13140	35907	87663	210242	503451	1081061	996798	1985568
	6	197	365	997	2226	5840	15959	38961	93441	228127	623384	877729	1814109
750	1	4926	9125	24935	53072	107223	199641	331228	531767	850175	1427785	1083481	2110391
	2	2189	4056	11082	24731	64890	156777	288364	488903	807310	1384921	1072765	2094959
	3	1231	2281	6234	13911	36500	99741	228354	428893	747301	1324911	1057762	2073355
	4	547	1014	2771	6183	16222	44330	108226	259558	575844	1153454	1014897	2011630
	5	308	570	1558	3478	9125	24935	60877	146002	356449	913415	954886	1925214
	6	137	253	693	1546	4056	11082	27057	64890	158422	432905	783426	1678313
1000	1	2771	5133	14026	31300	80552	172970	304557	505096	823504	1401114	1076813	2100789
	2	1231	2281	6234	13911	36500	99741	228354	428893	747301	1324911	1057762	2073355
	3	693	1283	3507	7825	20531	56105	136974	322209	640616	1218227	1031090	2034948
	4	308	570	1558	3478	9125	24935	60877	146002	356449	913415	954886	1925214
	5	173	321	877	1956	5133	14026	34243	82126	200503	547896	848200	1771587
	6	77	143	390	869	2281	6234	15219	36500	89112	243509	543396	1332650
1250	1	1773	3285	8977	20032	52561	138678	270265	470804	789212	1366823	1068240	2088444
	2	788	1460	3990	8903	23360	63835	155846	351737	670145	1247755	1038473	2045579
	3	443	821	2244	5008	13140	35907	87663	210242	503451	1081061	996798	1985568
	4	197	365	997	2226	5840	15959	38961	93441	228127	623384	877729	1814109
	5	111	205	561	1252	3285	8977	21916	52561	128322	350653	711032	1574065
	6	49	91	249	556	1460	3990	9740	23360	57032	155846	347773	912510
1500	1	1231	2281	6234	13911	36500	99741	228354	428893	747301	1324911	1057762	2073355
	2	547	1014	2771	6183	16222	44330	108226	259558	575844	1153454	1014897	2011630
	3	308	570	1558	3478	9125	24935	60877	146002	356449	913415	954886	1925214
	4	137	253	693	1546	4056	11082	27057	64890	158422	432905	783426	1678313
	5	77	143	390	869	2281	6234	15219	36500	89112	243509	543396	1332650
	6	34	63	173	386	1014	2771	6764	16222	39605	108226	241509	633688
1750	1	905	1676	4580	10220	26817	73279	178905	379361	697769	1275379	1045379	2055524
	2	402	745	2036	4542	11918	32569	79513	190696	464397	1042007	987035	1971508
	3	226	419	1145	2555	6704	18320	44726	107266	261881	715619	905353	1853887
	4	101	186	509	1136	2980	8142	19878	47674	116392	318053	671978	1517827
	5	57	105	286	639	1676	4580	11182	26817	65470	178905	399230	1047524
	6	25	47	127	284	745	2036	4970	11918	29098	79513	177435	465566
2000	1	693	1283	3507	7825	20531	56105	136974	322209	640616	1218227	1031090	2034948
	2	308	570	1558	3478	9125	24935	60877	146002	356449	913415	954886	1925214
	3	173	321	877	1956	5133	14026	34243	82126	200503	547896	848200	1771587
	4	77	143	390	869	2281	6234	15219	36500	89112	243509	543396	1332650
	5	43	80	219	489	1283	3507	8561	20531	50126	136974	305660	802011
	6	19	36	97	217	570	1558	3805	9125	22278	60877	135849	356449
2250	1	547	1014	2771	6183	16222	44330	108226	259558	575844	1153454	1014897	2011630
	2	243	451	1231	2748	7210	19702	48101	115359	281639	767677	918451	1872748
	3	137	253	693	1546	4056	11082	27057	64890	158422	432905	783426	1678313
	4	61	113	308	887	1802	4926	12025	28840	70410	192402	429350	1122784
	5	34	63	173	386	1014	2771	6764	16222	39605	108226	241509	633688
	6	15	28	77	172	451	1231	3006	7210	17602	48101	107337	218639
2500	1	443	821	2244	5008	13140	35907	87663	210242	503451	1081061	996798	1985568
	2	197	365	997	2226	5840	15959	38961	93441	228127	623384	877729	1814109
	3	111	205	561	1252	3285	8977	21916	52561	128322	350653	711032	1574065
	4	49	91	249	556	1460	3990	9740	23360	57032	155846	347773	912510
	5	28	51	140	313	821	2244	5479	13140	32080	87663	195623	513287
	6	12	23	62	139	365	997	2435	5840	14258	38961	86943	228127
2750	1	366	679	1855	4139	10860	29675	72449	173754	424204	1001048	976795	1956763
	2	163	302	824	1839	4827	13189	32200	77224	188535	515193	832721	1749297
	3	92	170	464	1035	2715	7419	18112	43438	106051	289796	631018	1458844
	4	41	75	206	460	1207	3297	8050	19306	47134	128798	287416	754141
	5	23	42	116	259	679	1855	4528	10860	26513	72449	161671	424204
	6	10	19	52	115	302	824	2012	4827	11783	32200	71854	188535
3000	1	308	570	1558	3478	9125	24935	60877	146002	356449	913415	954886	1925214
	2	137	253	693	1546	4056	11082	27057	64890	158422	432905	783426	1678313
	3	77	143	390	869	2281	6234	15219	36500	89112	243509	543396	1332650
	4	34	63	173	386	1014	2771	6764	16222	39605	108226	241509	633688
	5	19	36	97	217	570	1558	3805	9125	22278	60877	135849	356449
	6	9	16	43	97	253	693	1691	4056	9901	27057	60377	158422

See page 13 for instructions in the use of this chart.

FLANGE AND LUG MOUNTINGS

Front Head Flange Mount – Style FHF

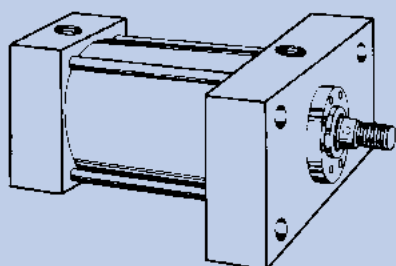

(ISO style ME5)

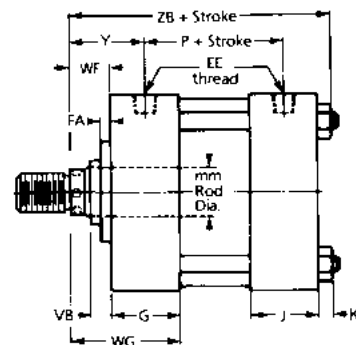
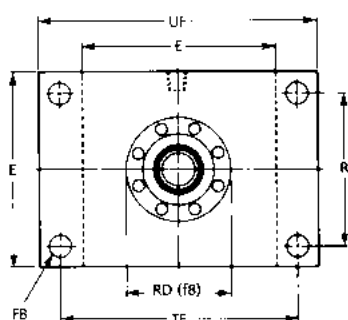

Rear Head Flange Mount – Style RHF

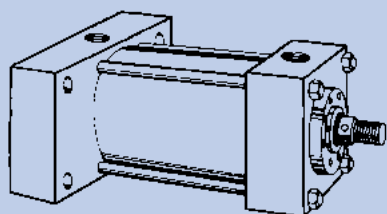

(ISO & DIN style ME6)

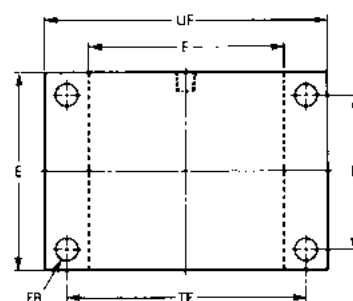
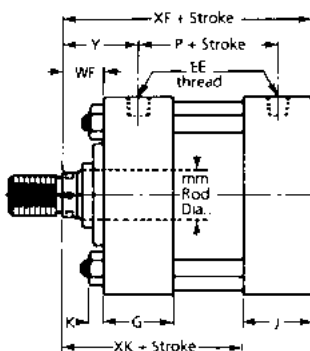

Side Lug Mount – Style SL

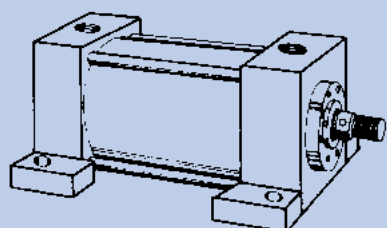

(ISO & DIN style MS2)

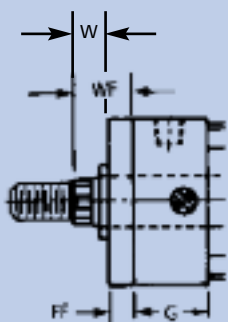
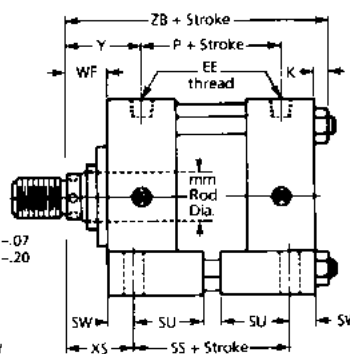
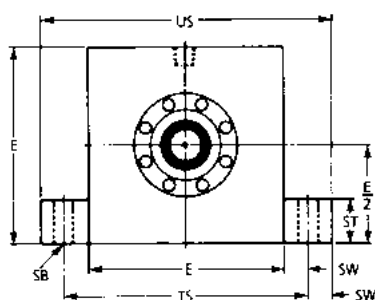

Drawing A

Important Notice

1. There is a construction variance in 25, 32, 40, 50 & 63 bore sizes and in the 80 bore with 45 and 56 dia. rods and 100 bore with 56 and 70 dia. rods in both RHF & SL mounts. In addition, the same applies to the FHF mount with 25, 32 and 40 bore size. The round retainer shown above is not used on these sizes. Instead, a retainer the same size as the head is used. See drawing A.
FHF Mount - The tie rods thread into the retainer. RHF Mount-The retainer is

cleared for the tie rods and held in place with the tie rod nuts. In these sizes, the rod gland cannot be removed without loosening the tie rods. SL Mount - The retainer is held in place with screws that thread into the head. Dimensions are shown on the adjacent drawing. On all other sizes, a round rod gland retainer is used. It is held in place by retainer screws - independent of the tie rods, hence, the rod gland can be removed without loosening the tie rods.

FLANGE AND LUG DIMENSIONS

Be sure to add Stroke to these Dimensions

Bore	MM Rod Dia.	FA	RD(f8)	VB	W	WF	WG	XF	XK	XS	FF	ZB
25	12	-	-	16	15	25	55	114	89	33	10	118
	18	-	-	16	15	25	55	114	89	33	10	118
32	14	-	-	22	25	35	65	128	103	45	10	133
	22	-	-	22	25	35	65	128	103	45	10	133
40	18	-	-	16	25	35	77	153	115	45	10	160
	28	-	-	22	25	35	77	153	115	45	10	160
50	22	16**	74**	22	25	41	83	159	121	54	16	169
	28	16**	74**	22	25	41	83	159	121	54	16	169
	36	16**	74**	25	25	41	83	159	121	54	16	169
63	28	16**	75**	22	32	48	90	168	130	65	16	178
	36	16**	88**	25	32	48	90	168	130	65	16	178
	45	16**	88**	29	32	48	90	168	130	65	16	178
80	36	20	82	25	31	51	101	190	145	68	-	203
	45	20**	105**	29	31	51	101	190	145	68	20	203
	56	20**	105**	29	31	51	101	190	145	68	20	203
100	45	22	92	29	35	57	107	203	158	79	-	216
	56	22**	125**	29	35	57	107	203	158	79	22	216
	70	22**	125**	32	35	57	107	203	158	79	22	216
125	56	22	105	29	35	57=	107	232	187	79	-	234
	70	22	150	32	35	57=	107	232	187	79	-	234
	90	22	150	32	35	57=	107	232	187	79	-	234
160	70	25	125	32	32	57	117	245	185	86	-	267
	90	25	170	32	32	57	117	245	185	86	-	267
	110	25	170	32	32	57	117	245	185	86	-	267
200	90	25	150	32	32	57	137	299	219	92	-	323
	110	25	210	32	32	57	137	299	219	92	-	323
	140	25	210	32	32	57	137	299	219	92	-	323

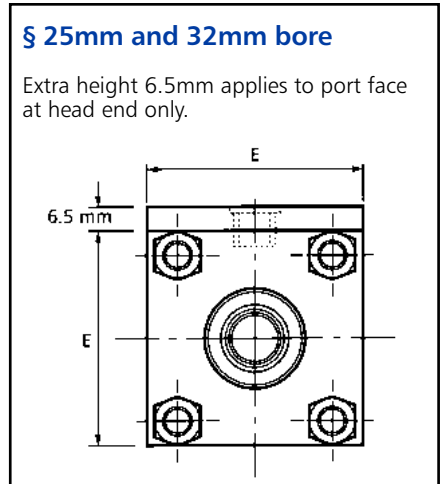

§ 25mm and 32mm bore
Extra height 6.5mm applies to port face at head end only.

Refer to pages 10-11 for important information concerning the mounting of cylinders.
Refer to page 25 for rod end information.

Note - Port positions other than 1 and 5 are not available in small bore sizes with style SL. Consult factory.

Be sure to add Stroke to these Dimensions

Bore	E	EE (BSP)	FB _m	G	J	K	P	R	SB	SS	ST	SU	SW	TF	TS	UF	US	Y*
25	38§	1/4	5.5	30	25	4	62	27	6.6	73	9	22	8	51	54	62	70	41
32	45§	1/4	6.6	30	25	5	66	33	9	73	12	20	10	58	63	70	84	51
40	63	3/8	11	42	38	6.5	78	41	11	98	12	32	10	87	83	110	103	57
50	76	1/2	14	42	38	10	78	52	14	92	18.5	29	13	105	102	130	127	63
63	89	1/2	14	42	38	10	80	65	18	86	25	25	17	117	124	140	159	70
80	115	3/4	18	50	45	13	88	83	18	105	25	33	17	149	149	180	185	79
100	127	3/4	18	50	45	13	95	97	26	102	31	28	22	162	172	195	216	85
125	165	3/4*	22	50	45	18	108	126	26	115	31	28	22	208	210	250	254	85=
160	203	1	26	60	60	22	128	155	33	130	37.5	31	29	253	260	300	317	87
200	240	1 1/4	33	80	80	29	162	190	39	172	44	45	35	300	311	360	367	97

** FHF Style Mount ONLY * Not in accordance with Standard = Add 16mm to this dimension for RHF Style Mount ONLY.

_m Clearance holes for indicated bolt size.

Important Notice

- 25 & 32 mm bore cylinders have head height increased by 6.5 mm on port face. See diagram.
- Due to space limitation on SL mount, ports can only be provided in positions 1 & 5 on 25 & 32 bore cylinders.
- The dimensions offered for Front Head Flange Mount - style FHF relate to ISO dimensions only. For DIN standard details please consult factory.
- For DIN 24554 standard please check model number composition on page 30.

Trunnion Front Mount – Style TF

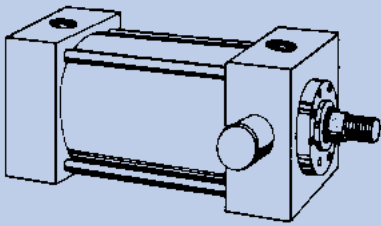

(ISO style MT1)

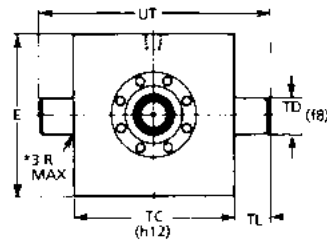

*25Ø | 1.5 R
32Ø |

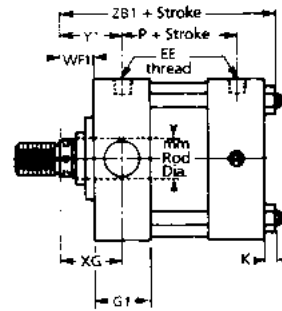

Trunnion Rear Mount – Style TR

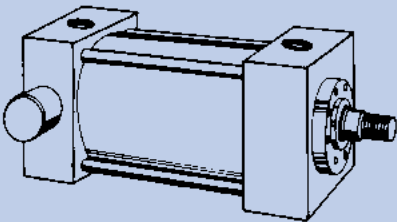

(ISO style MT2)

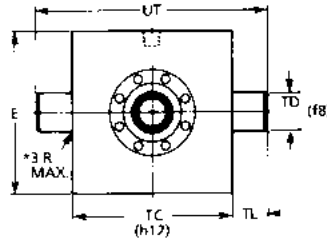

*25Ø | 1.5 R
32Ø |

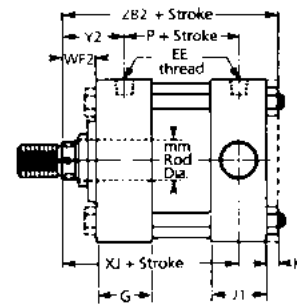

Trunnion Mount – Style T

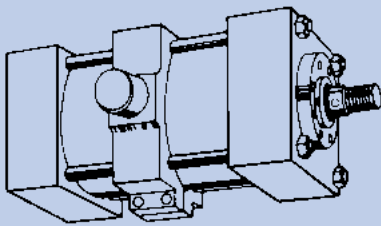

(intermediate-Between Heads)
Position NOT Adjustable

(ISO & DIN style MT4)

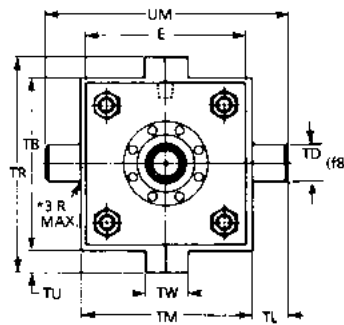

*25Ø | 1.5 R
32Ø | MAX.

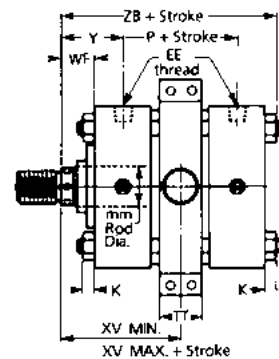

Important Notice

- There is a construction variance in 25, 32, 40, 50 & 63 bore sizes and the 80mm bore with 45 and 56 dia. rods. The round retainer shown above is not used on these sizes. Instead, a retainer the same size as the head is used. See drawing A on opposite page.
- In the T mount, note 1 above also applies to the 100 bore with 56 and 70 dia. rods.
- In the TF and TR mounts, the retainer is held in place by retainer screws that thread into the head. The rod gland can be removed without loosening the tie rods.
- The T mount also employs a square retainer but it is held in place with the tie rod nuts. The rod gland cannot be removed without loosening the tie rods.
- In all mounts 100 bore and above which have a round retainer, this is held in place by screws independent of the tie rods, hence, the rod gland can be removed without loosening the tie rods.
- The TR mount upto and including 80 bore has tie rod nuts at rear and screws at the front. From 100 bore upwards, the tie rod nuts are located at the front.
- 25 & 32 mm bore cylinders have head height increased by 6.5 mm on port face. See opposite on dimension page.

TRUNNION DIMENSIONS

Be sure to add Stroke to these Dimensions

Bore	MM Rod Dia.	WF	XV Min.	XV Max	XG	XJ	Y*	ZB	FF
25	12	25	67	77	44	101	41	118	10
	18	25	67	77	44	101	41	118	10
32	14	35	79	89	54	115	51	133	10
	22	35	79	89	54	115	51	133	10
40	18	35	93	99	57	134	57	160	10
	28	35	93	99	57	134	57	160	10
50	22	41	104	100	64	140	63	169	16
	28	41	104	100	64	140	63	169	16
	36	41	104	100	64	140	63	169	16
63	28	48	111	109	70	149	70	178	16
	36	48	111	109	70	149	70	178	16
	45	48	111	109	70	149	70	178	16
80	36	51	127	119	76	168	79	203	-
	45	51	127	119	76	168	79	203	20
	56	51	127	119	76	168	79	203	20
100	45	57	138	128	71	187	85	216	-
	56	57	138	128	71	187	85	216	22
	70	57	138	128	71	187	85	216	22
125	56	57	146	132	75	209	85	234	-
	70	57	146	132	75	209	85	234	-
	90	57	146	132	75	209	85	234	-
160	70	57	166	136	75	230	87	267	-
	90	57	166	136	75	230	87	267	-
	110	57	166	136	75	230	87	267	-
200	90	57	199	157	85	276	97	323	-
	110	57	199	157	85	276	97	323	-
	140	57	199	157	85	276	97	323	-

§ 25mm and 32mm bore

Extra height 6.5mm applies to port face at head end only.

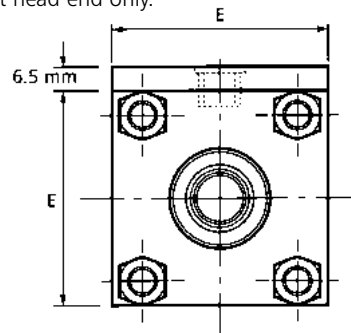

Refer to pages 10-11 for important information concerning the mounting of cylinders.

Refer to page 25 for rod end information.

Important Notice

For DIN 24554 standard please check model number composition on page 30.

Be sure to add Stroke to these Dimensions

Bore	E	EE (BSP)	G	J	K	P	TB	TD(f8)	TL	TM	TR	TT	TU	TW	UM	UT	TC
25	38§	1/4	30	25	4	62	60	12	10	48	60	22	-	46	68	58	38
32	45§	1/4	30	25	5	66	66	16	12	55	66	25	-	54	79	68	44
40	63	3/8	42	38	6.5	78	80	20	16	76	80	30	-	74	108	95	63
50	76	1/2	42	38	10	78	105	25	20	89	105	40	-	87	129	116	76
63	89	1/2	42	38	10	80	125	32	25	100	125	40	-	98	150	139	89
80	115	3/4	50	45	13	88	120	40	32	127	160	50	20	64	191	178	114
100	127	3/4	50	45	13	95	136	50	40	140	178	60	21	64	220	207	127
125	165	3/4*	50	45	18	108	168	63	50	178	210	76	21	64	278	265	165
160	203	1	60	60	22	128	212	80	63	215	260	95	24	64	341	329	203
200	240	1 1/4	80	80	29	162	277	100	80	279	330	120	26.5	64	439	401	241

*Not in accordance with Standard.

Be sure to add Stroke to these Dimensions

Bore	G1	J1	WF1	WF2	Y1	Y2	ZB1	ZB2 Max.
25	30	25	25	25	41	41	118	121
32	30	25	35	35	51	51	133	137
40	42	38	35	35	57	57	160	166
50	42	38	41	41	63	63	169	176
63	42	38	48	48	70	70	178	185
80	50	45	51	51	79	79	203	212
100	58	58	42	57	78	85	209	225
125	72	72	39	59	89	87	238	260
160	90	90	30	57	90	87	270	279
200	110	110	30	59	100	99	326	336

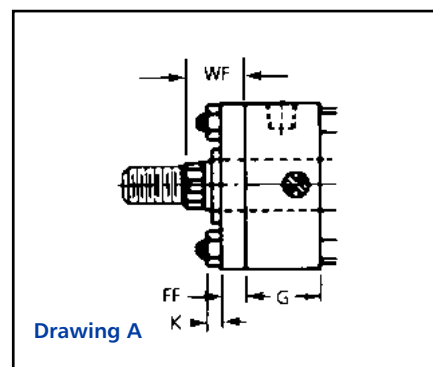

Drawing A

CLEVIS AND PIVOT MOUNTINGS

Clevis Mount – Style C

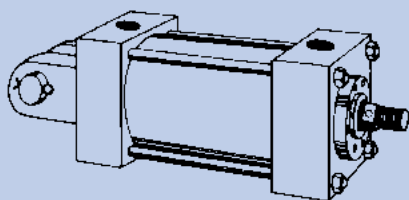

(ISO style MP1)

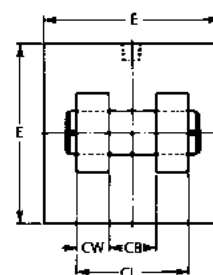
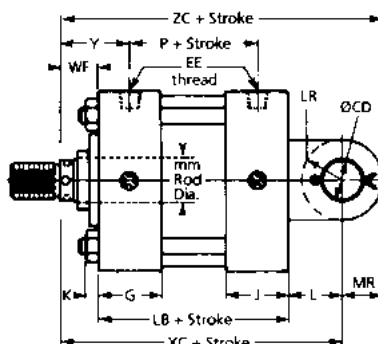

Supplied complete with Pivot pin

Pivot Mount – Style P

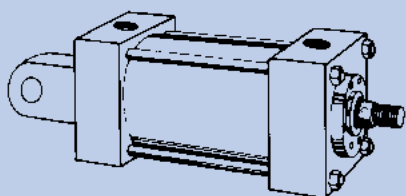

(ISO style MP3)

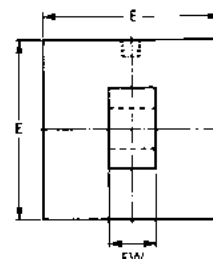
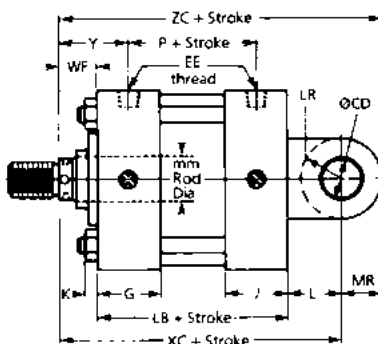

Pivot pin not supplied

Pivot Mount with Spherical Bearing – Style SBp

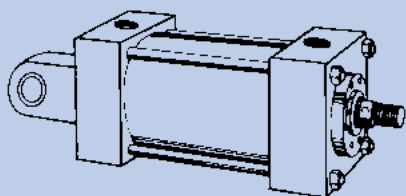

(ISO & DIN style MP5)

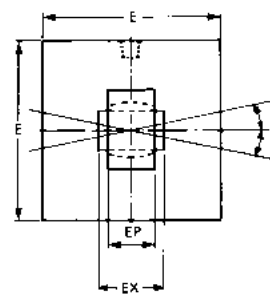
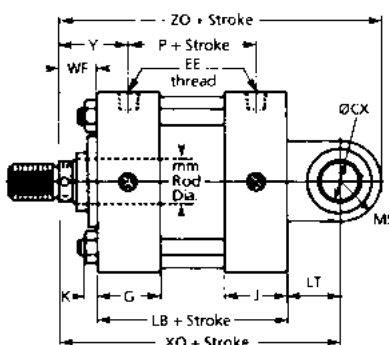

Pivot pin not supplied

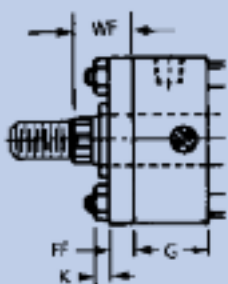

Drawing A

Important Notice

1. There is a construction variance in 25, 32, 40, 50 & 63 bore sizes and in the 80 bore with 45 and 56 dia. rods and 100 bore with 56 and 70 dia. rods. The round retainer shown above is not used on these sizes.

A square retainer, the same square size as the head is used. See drawing A. The retainer is cleared for the tie rods and held in place with the tie rod nuts. In these sizes, the rod gland cannot be removed without loosening the tie rods.

Dimensions are shown on the adjacent drawing.

On all other sizes, a round rod gland retainer is used. It is held in place by retainer screws - independent of the tie rods, hence, the rod gland can be removed without loosening the tie rods.

2. 25 & 32 mm bore cylinders have head height increased by 6.5 mm on port face. See opposite on dimension page.

CLEVIS AND PIVOT DIMENSIONS

Be sure to add Stroke to these Dimensions

Bore	MM Rod Dia.	WF	XC	XO	Y*	ZC	ZO	FF
25	12	25	127	130	41	139	150	10
	18	25	127	130	41	139	150	10
32	14	35	147	148	51	163	170	10
	22	35	147	148	51	163	170	10
40	18	35	172	178	57	188	207	10
	28	35	172	178	57	188	207	10
50	22	41	191	190	63	216	223	16
	28	41	191	190	63	216	223	16
	36	41	191	190	63	216	223	16
63	28	48	200	206	70	225	246	16
	36	48	200	206	70	225	246	16
80	45	48	200	206	70	225	246	16
	36	51	229	238	79	262	288	-
	45	51	229	238	79	262	288	20
100	56	51	229	238	79	262	288	20
	45	57	257	261	85	302	323	-
	56	57	257	261	85	302	323	22
125	70	57	257	261	85	302	323	22
	56	73	289	304	101	340	384	-
	70	73	289	304	101	340	384	-
160	90	73	289	304	101	340	384	-
	70	57	308	337	87	365	437	-
	90	57	308	337	87	365	437	-
200	110	57	308	337	87	365	437	-
	90	57	381	415	97	457	535	-
	110	57	381	415	97	457	535	-
	140	57	381	415	97	457	535	-

§ 25mm and 32mm bore

Extra height 6.5mm applies to port face at head end only.

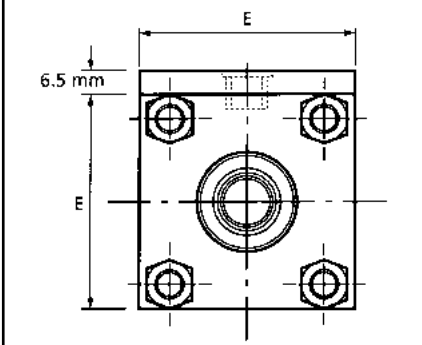

Refer to pages 10-11 for important information concerning the mounting of cylinders.

Refer to page 25 for rod end information.

Important Notice

For DIN 24554 standard please check model number composition on page 30.

Be sure to add Stroke to these Dimensions

Bore	CB	CD	CL Max.	CW Ref.	CX	E	EE (BSP)	EP	EW	EX	G	J	K	L	LB	LR	LT	MR	MS	P	Z
25	12	10	26	7	12	38§	1/4	8	12	10	30	25	4	13	89	12	16	12	20	62	3°
32	16	12	34	9	16	45§	1/4	11	16	14	30	25	5	19	93	16	20	16	22.5	66	
40	20	14	42	11	20	63	3/8	13	20	16	42	38	6.5	19	118	16	25	16	29	78	
50	30	20	62	16	25	76	1/2	17	30	20	42	38	10	32	118	25	31	25	33	78	
63	30	20	62	16	30	89	1/2	19	30	22	42	38	10	32	120	25	38	25	40	80	
80	40	28	83	21	40	115	3/4	23	40	28	50	45	13	39	139	33	48	33	50	88	
100	50	36	103	26	50	127	3/4	30	50	35	50	45	13	54	146	45	58	45	62	95	
125	60	45	123	31	60	165	3/4*	38	60	44	50	45	18	57	159	51	72	51	80	108	
160	70	56	143	36	80	203	1	47	70	55	60	60	22	63	188	57	92	57	100	128	
200	80	70	163	41	100	240	1.1/4	57	80	70	80	80	29	82	242	76	116	76	120	162	

*Not in accordance with Standard.

Tie Rod Extended Both Ends – Style BX

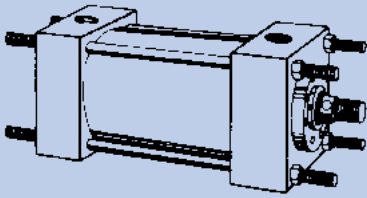

(ISO style MX1)

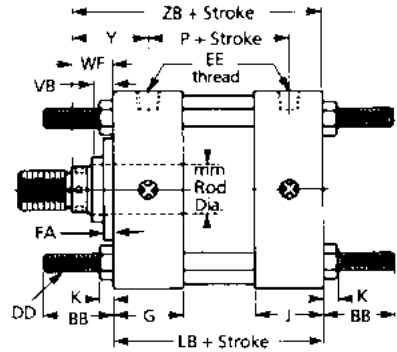
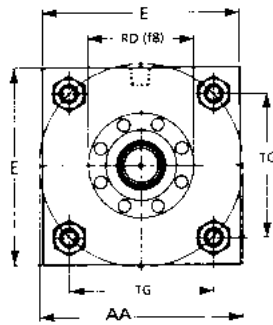

Tie Rod Extended Head End – Style FX

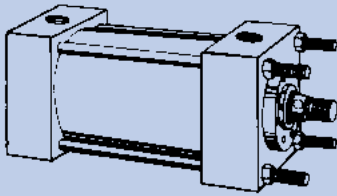

(ISO style MX3)

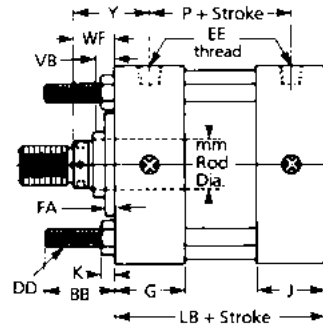
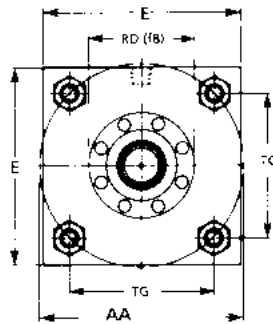

Tie Rod Extended Cap End – Style RX

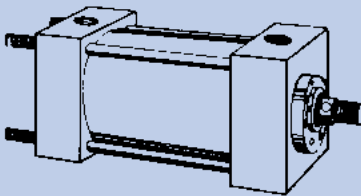

(ISO style MX2)

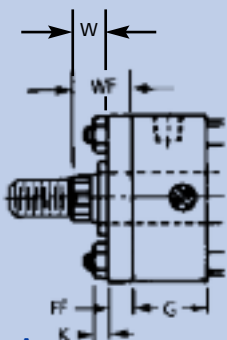
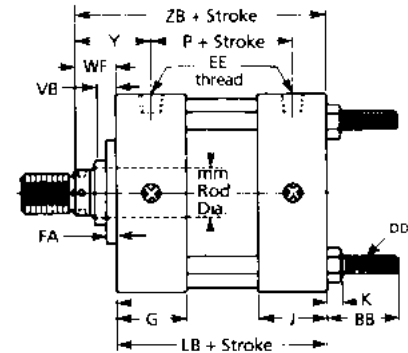
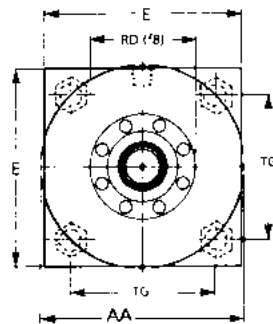

Drawing A

Important Notice

1. There is a construction variance in 25, 32, 40, 50 & 63 bore sizes and in the 80 bore with 45 and 56 dia. rods and 100 bore with 56 and 70 dia. rods. The round retainer shown above is not used on these sizes. See drawing A. The tie rod nuts are therefore tightened against the retainer instead of against the head on the FX and BX Mounts and the rod gland cannot be removed without loosening the tie rods. See adjacent drawing. On the NX and RX Mounts, the square retainer is also used as shown on the adjacent drawing,

but the retainer is held in place with retainer screws. The tie rods thread into the head. The rod gland can be removed without loosening the tie rods in these mounts. Dimensions are shown on the adjacent drawing.

On all other sizes, a round rod gland retainer is used. It is held in place by retainer screws - independent of the tie rods, hence, the rod gland can be removed without loosening the tie rods.

2. 25 & 32 mm bore cylinders have head height increased by 6.5 mm on port face. See opposite on dimension page.

TIE ROD DIMENSIONS

Bore	MM Rod Dia.	FA	RD(f8)	VB	W	WF	Y*	ZB	FF
25	12	-	-	16	15	25	41	114	10
	18	-	-	16	15	25	41	114	10
32	14	-	-	22	25	35	51	128	10
	22	-	-	22	25	35	51	128	10
40	18	-	-	16	25	35	57	153	10
	28	-	-	22	25	35	57	153	10
50	22	-	-	22	25	41	63	159	16
	28	-	-	22	25	41	63	159	16
	36	-	-	25	25	41	63	159	16
63	28	-	-	22	32	48	70	168	16
	36	-	-	25	32	48	70	168	16
	45	-	-	29	32	48	70	168	16
80	36	20	82	25	31	51	79	190	-
	45	-	-	29	31	51	79	190	20
	56	-	-	29	31	51	79	190	20
100	45	22	92	29	35	57	85	203	-
	56	-	-	29	35	57	85	203	22
	70	-	-	32	35	57	85	203	22
125	56	22	105	29	35	57	85	216*	-
	70	22	125	32	35	57	85	216*	-
	90	22	150	32	35	57	85	216*	-
160	70	25	125	32	32	57	87	245	-
	90	25	170	32	32	57	87	245	-
	110	25	170	32	32	57	87	245	-
200	90	25	150	32	32	57	97	299	-
	110	25	210	32	32	57	97	299	-
	140	25	210	32	32	57	97	299	-

§ 25mm and 32mm bore

Extra height 6.5mm applies to port face at head end only.

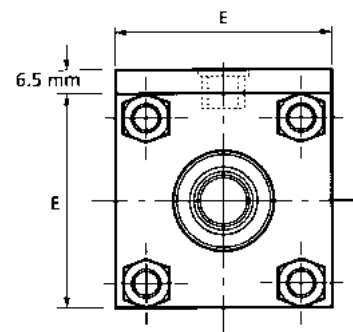

Refer to pages 10-11 for important information concerning the mounting of cylinders.

Refer to page 25 for rod end information.

Important Notice

For DIN 24554 standard please check model number composition on page 30.

Be sure to add Stroke to these Dimensions

Bore	AA	BB	DD	E	EE (BSP)	G	J	K	LB	P	TG
25	40	19	M5 x 0.8	38§	1/4	30	25	4	89	62	28.3
32	47	24	M6 x 1	45§	1/4	30	25	5	93	66	33.2
40	59	35	M8 x 1	63	3/8	42	38	6.5	118	78	41.7
50	74	46	M12 x 1.25	76	1/2	42	38	10	118	78	52.3
63	91	46	M12 x 1.25	89	1/2	42	38	10	120	80	64.3
80	117	59	M16 x 1.5	115	3/4	50	45	13	139	88	82.7
100	137	59	M16 x 1.5	127	3/4	50	45	13	146	95	96.9
125	178	81	M22 x 1.5	165	3/4*	50	45	18	159	108	125.9
160	219	92	M27 x 2	203	1	60	60	22	188	128	154.9
200	269	115	M30 x 2	240	1 1/4	80	80	29	242	162	190.2

*Not in accordance with Standard.

Basic Double Rod Extension

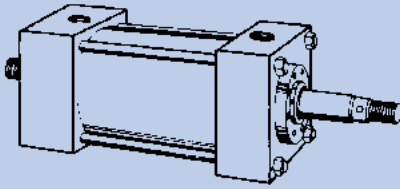

Available in all except C & P & RHF mounts.

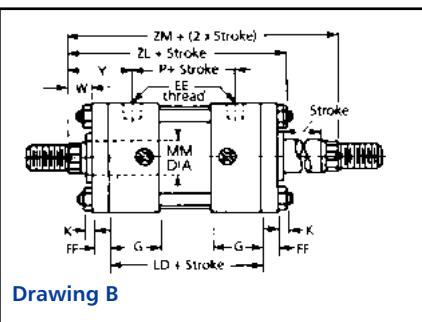
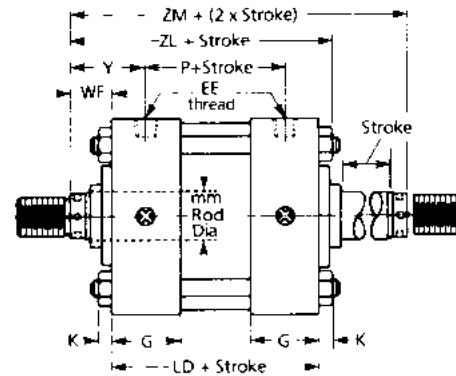
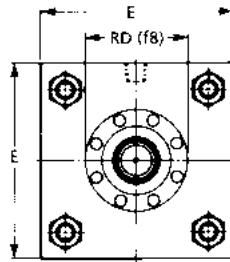

Drawing B

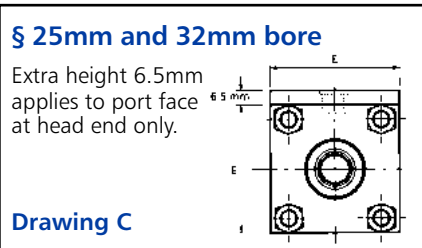

Drawing C

Important Notice

1. There is a construction variance in 25, 32, 40, 50 & 63 bore sizes and in the 80 bore with 45 and 56 dia. rods and 100 bore with 56 and 70 dia. rods. The round retainer shown above is not used on these sizes.

A square retainer, the same square size as the head is employed. The retainer is cleared for the tie rods and held in place with the tie rod nuts. See drawing B. In these sizes, the rod gland cannot be removed without loosening the tie rods. Dimensions are shown on the adjacent drawing.

On all other sizes, a round rod gland retainer is used. It is held in place by retainer screws - independent of the tie rods, hence, the rod gland can be removed without loosening the tie rods.

2. 25 & 32 mm bore cylinders have head height increased by 6.5 mm on port

face. See drawing C.

3. When the rod ends of a double rod end cylinder are not to be the same, such as a style 2 on one end and a style 4 on the other, be sure to so specify and identify which end is which in relation to the mount.

For example, on a Front Head Flange mount double rod end cylinder, specify style 2 rod end on flange end of cylinder and style 4 on opposite end.

4. For 25, 32 and 40 bore sizes one rod end is marked with the letter M. This rod can take a full load of 210 bar. The opposite end is restricted to 140 bar. Please clearly state which end full load is to be applied.

5. Refer to **page 25** for Rod End Information.

6. For double rod style SL mounts consult factory for dimensions.

Be sure to add Stroke to these Dimensions
Add 2X Stroke to ZM Dimension

Bore	MM Rod Dia.	E	EE (BSP)	G	K	LD	P	RD	W	WF	Y*	ZL	ZM	FF
25	12	38§	1/4	30	4	94	62	-	15	25	41	123	144	10
	18	38§	1/4	30	4	94	62	-	15	25	41	123	144	10
32	14	45§	1/4	30	5	98	66	-	25	35	51	138	168	10
	22	45§	1/4	30	5	98	66	-	25	35	51	138	168	10
40	18	63	3/8	42	6.5	122	78	-	25	35	57	164	192	10
	28	63	3/8	42	6.5	122	78	-	25	35	57	164	192	10
50	22	76	1/2	42	10	122	78	-	25	41	63	173	204	16
	28	76	1/2	42	10	122	78	-	25	41	63	173	204	16
63	36	76	1/2	42	10	122	78	-	25	41	63	173	204	16
	28	89	1/2	42	10	124	80	-	32	48	70	182	220	16
80	36	89	1/2	42	10	124	80	-	32	48	70	182	220	16
	45	89	1/2	42	10	124	80	-	32	48	70	182	220	16
100	36	115	3/4	50	13	144	88	82	31	51	79	208	246	-
	45	115	3/4	50	13	144	88	-	31	51	79	208	246	20
125	56	115	3/4	50	13	144	88	-	31	51	79	208	246	20
	45	127	3/4	50	13	151	95	92	35	57	85	221	265	-
160	56	127	3/4	50	13	151	95	-	35	57	85	221	265	22
	70	127	3/4	50	13	151	95	-	35	57	85	221	265	22
200	56	165	3/4*	50	18	164	108	105	35	57	85	239	278	-
	70	165	3/4*	50	18	164	108	125	35	57	85	239	278	-
240	90	165	3/4*	50	18	164	108	150	35	57	85	239	278	-
	70	203	1	60	22	188	128	125	32	57	87	267	302	-
280	90	203	1	60	22	188	128	170	32	57	87	267	302	-
	110	203	1	60	22	188	128	170	32	57	87	267	302	-
320	90	240	1 1/4	80	29	242	162	150	32	57	97	323	356	-
	110	240	1 1/4	80	29	242	162	210	32	57	97	323	356	-
360	140	240	1 1/4	80	29	242	162	210	32	57	97	323	356	-

*Not in accordance with Standard.

ROD END INFORMATION

Standard – Style 2

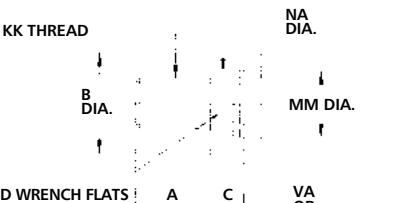

Male thread with adequate shoulder for locking accessory.

Alternate – Style 4

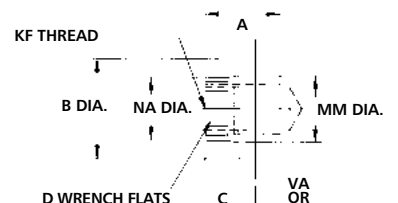

Female thread, used with male accessories for shorter overall cylinder length.

Important

Specify on order

1. Type of thread
2. Length of thread
3. Rod extension if non-standard
4. Any non standard thread please specify style 3 and supply full details. ie. rod thread, male/female, thread length etc.

ISO 6020/2									
Bore	MM Rod Dia.	A	B Dia.(f8)	C	D	KK	NA ⁺⁰ _{-0.1}	V	KF
25	12	14	24	9	10	M10 x 1.25	11	6	M8 X 1
	18	18	30	9	15	M14 x 1.5	17	6	M12 X 1.25
32	14	16	26	13	12	M12 x 1.25	13	12	M10 X 1.25
	22	22	34	13	18	M16 x 1.5	21	12	M16 X 1.5
40	18	18	30	19	15	M14 x 1.5	17	6	M12 X 1.25
	28	28	42	13	22	M20 x 1.5	27	12	M20 x 1.5
50	22	22	34	19	18	M16 x 1.5	21	6	M16 x 1.5
	28	28	42	19	22	M20 x 1.5	27	6	M20 x 1.5
	36	36	50	16	30	M27 x 2	34	9	M27 x 2
63	28	28	42	26	22	M20 x 1.5	27	6	M20 x 1.5
	36	36	50	23	30	M27 x 2	34	9	M27 x 2
	45	45	60	19	39	M33 x 2	43	13	M33 x 2
80	36	36	50	26	30	M27 x 2	34	5	M27 x 2
	45	45	60	22	39	M33 x 2	43	9	M33 x 2
	56	56	72	22	48	M42 x 2	54	9	M42 x 2
100	45	45	60	28	39	M33 x 2	43	7	M33 x 2
	56	56	72	28	48	M42 x 2	54	7	M42 x 2
	70	63	88	25	62	M48 x 2	68	10	M48 x 2
125	56	56	72	28	48	M42 x 2	54	7	M42 x 2
	70	63	88	25	62	M48 x 2	68	10	M48 x 2
	90	85	108	25	80	M64 x 3	88	10	M64 x 3
160	70	63	88	25	62	M48 x 2	68	7	M48 x 2
	90	85	108	25	80	M64 x 3	88	7	M64 x 3
	110	95	133	25	100	M80 x 3	108	7	M80 x 3
200	90	85	108	25	80	M64 x 3	88	7	M64 x 3
	110	95	133	25	100	M80 x 3	108	7	M80 x 3
	140	112	163	25	128	M100 x 3	138	7	M100 x 3

DIN 24554 (Style 2 only)									
Bore	MM Rod Dia.	A	B Dia.(f8)	C	D	KK	NA ⁺⁰ _{-0.1}	V	
25	12	14	24	9	10	M10 x 1.25	11	6	
	18	14	30	9	15	M10 x 1.25	17	6	
32	14	16	26	13	12	M12 x 1.25	13	12	
	22	16	34	13	18	M12 x 1.25	21	12	
40	18	18	30	19	15	M14 x 1.5	17	6	
	28	18	42	13	22	M14 x 1.5	27	12	
50	22	22	34	19	18	M16 x 1.5	21	6	
	28	22	42	19	22	M16 x 1.5	27	6	
	36	22	50	16	30	M16 x 1.5	34	9	
63	28	28	42	26	22	M20 x 1.5	27	6	
	36	28	50	23	30	M20 x 1.5	34	9	
	45	28	60	19	39	M20 x 1.5	43	13	
80	36	36	50	26	30	M27 x 2	34	5	
	45	36	60	22	39	M27 x 2	43	9	
	56	36	72	22	48	M27 x 2	54	9	
100	45	45	60	28	39	M33 x 2	43	7	
	56	45	72	28	48	M33 x 2	54	7	
	70	45	88	25	62	M33 x 2	68	10	
125	56	56	72	28	48	M42 x 2	54	7	
	70	56	88	25	62	M42 x 2	68	10	
	90	56	108	25	80	M42 x 2	88	10	
160	70	63	88	25	62	M48 x 2	68	7	
	90	63	108	25	80	M48 x 2	88	7	
	110	63	133	25	100	M48 x 2	108	7	
200	90	85	108	25	80	M64 x 3	88	7	
	110	85	133	25	100	M64 x 3	108	7	
	140	85	163	25	128	M64 x 3	138	7	

Standard – Style 2

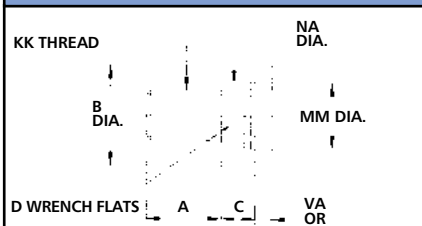

Male thread with adequate shoulder for locking accessory.

Any non standard thread please specify style 3 and supply full details. ie. rod thread, male/female, thread length etc.

INSTALLATION AND MAINTENANCE

Storage

If it is necessary to store a cylinder for a period of time prior to installation, the following procedures should be adhered to:

1. Do not store out of doors or in a high humidity or corrosive atmosphere without a positive method of internal and external corrosion protection.
2. Where any adverse storage conditions exist, coat all unpainted external parts, including the piston rod, with corrosion inhibitive material. Fill both ends of the cylinder with a corrosion preventative fluid compatible with the system fluid.
3. If possible, store the cylinder in a vertical position, piston rod up.
4. Dirt protector plugs should be kept in the ports during storage.

Installation

Details on each specific mount are given in our EH Series Catalogue and reference should be made to the section on "Mountings". In addition, the following general procedures should be followed:

1. On all rigidly mounted cylinders, be sure that the part which attaches to the piston rod exactly "lines up" with the piston rod travel, or make provision for axial misalignment.
2. Flange mounted cylinders should be solidly mounted to a rigid section of the machine with high tensile bolts (socket head type recommended). When a pilot diameter cannot be used for alignment, the cylinder must be aligned to the work, tightened in place, and the flange drilled for a dowel and pinned to prevent shifting. For horizontal installations of flange mount cylinders with 1200 mm of stroke and longer, we recommend supporting both ends of the cylinder.
3. Side mounted cylinders (Style SL) used under shock conditions or at high pressure ranges (over 103 bar) should be dowelled or keyed to the machine. Style SL has room for dowel pins in the mounting lugs. Cylinders should be pinned or keyed at one end only (especially important on long stroke cylinders) due to the deflection that takes place under load. On long stroke applications, the addition of an intermediate support (between the cylinder heads to support the tube and tie rods) is very important and is recommended. Care should be exercised in fastening the intermediate support so that no "humping" of the cylinder occurs. An intermediate support is utilized to afford additional cylinder support and is not designed to absorb thrust.
4. All clevis and trunnion mount cylinders need provisions on both ends for pivoting in one direction. Alignment in the other direction is essential to avoid excessive side loading. Where alignment in one direction is not possible, the cylinder must be equipped with two direction pivoting such as can be obtained with a spherical bearing.

5. On trunnion mount cylinders, use pillow blocks of ample size, rigidly mounted as close to the cylinder heads as possible. Bearing should be provided for the full length of the trunnion pins. Lubrication should be provided to the pins.

Bleeding

If a cylinder is equipped with optional air bleeds, after the cylinder has been fully connected and the system has been filled with fluid, cycle the cylinder and bleed the air by loosening the air bleed plugs alternately. Loosen just enough to release the air bubbles. Tighten when no more air escapes.

Maintenance

Please note when doing maintenance work on EH series cylinders:

1. The tie rod nuts need not be loosened or removed to service the rod bearing or gland except on mounting styles, BX, C, FX, RHF and T on 25, 32, 40, 50 & 63 bores and in the 80 bore with a 56 dia. rod and 100 bore with a 70 dia. rod.
2. One piece piston construction eliminates the need for removing the piston from the piston rod.
3. All parts removed from the cylinder that are to be re-used should be thoroughly cleaned. Be sure to carefully clean all cavities and grooves prior to replacing parts. All parts, new and old, should be lightly lubricated with a clean lubricant of the same type as, or compatible with, the fluid being used in the cylinder.
4. When a cylinder is disassembled, it is a good practice to replace all static and moving seals.

TO REPLACE ROD BEARING, ROD PACKING, ROD WIPER, OR ROD GLAND SEAL extend the piston rod (item 3) 1/4 of the stroke. CAUTION! Support the rod end at all times to prevent nicking and to avoid cocking the piston in the tube. Inspect the piston rod wrench flats for burrs. Remove any burrs to prevent damage to the rod packing, rod wiper, or bearing when it is slipped off the rod. Remove rod packing gland retainer screws (item 10) and the rod gland retainer (item 6) or the rod gland (item 6A) on the single piece construction.

After the gland or gland retainer has been removed, the rod packing may be removed from the gland. Place the rod gland on a clean, flat surface with the rod packing end up. Use a small screwdriver to remove the rod packing set (item 25) being careful not to nick or scratch the bore of the packing cavity. Remove the rod wiper in the same manner, being careful not to nick or scratch the wiper cavity. When replacing the rod wiper be sure it is fully seated in the groove. When replacing the rod packing, apply a light coating of clean lubricant to the new seal and insert it into the gland firmly with the fingers.

To remove the rod bearing (item 21), first remove the rod gland seal (item 22). This will expose the chamfer on the outside edge of the bearing against the head. Place two small pry bars or screwdrivers into the chamfer and pry the bearing gently out of the cylinder. Be sure to support the end of the rod. Inspect the bearing and rod for scoring, galling, etc. Replace any damaged parts. Replace the bearing by pushing or lightly tapping with a plastic hammer until its seated into the head. Lubricate the gland seal and place around the bearing. Slide the rod packing gland onto the rod taking care that the rod packing set is not damaged when being passed over the rod end threads and wrench flats. Be careful that the gland seal is not pinched or cut as the packing gland is brought up against the head. Replace the gland retainer screws. See chart for proper torque value for retainer screws. If the tie rod nuts have been removed, tighten them using the values shown on the tie rod torque chart. If the piston packings or tube seals are to be serviced, do not replace the rod gland or bearing until this service has been completed.

TO REPLACE TUBE SEALS, PISTON SEAL, AND PISTON BEARING STRIP. Remove the tie rod nuts (item 13) and remove the tie rods (item 5) CAUTION! Support the piston rod and piston assembly at all times. Remove the cap (item 2) and the tube (item 4). Examine the tube seals (item 16) for nicks, cuts, or grooves, and replace if necessary. The new seals should be lubricated before inserting into the grooves. (NOTE: When a cylinder has been disassembled to this degree, it is always wise to replace all seals and bearings.)

If the cylinder has a Teflon piston seal and bearing strip, cut the piston seal (item 18A) to remove from groove, being careful not to nick or scratch the sides of the groove. Remove the expander ring (item 18B) using a blunt screwdriver, again being careful not to damage bottom or sides of groove. For ease of installation and to minimise the time the piston seal is in the stretched condition, the expander and piston seal should be placed into the groove from the rod side of the piston. The leading edge of the piston at the top of the chamfer must be free of any deep nicks or burrs, before installing the piston seal. Lubricate this edge prior to putting the piston seal into the groove. Lightly lubricate the expander and stretch it over the end of the piston into the groove. Lift a segment of the piston seal over the lips of the piston and place as much of the seal into the groove as possible by pushing down on the outside of the ring to seat the I.D. on the expander. Place a small rod or screwdriver without sharp edges or points under the I.D. of the piston seal that is outside the groove. Pulling outward and inward toward the piston, stretch the seal up and over the lip to align it with the groove. Remove the screwdriver and the seal will snap into the groove. The stretching of the seal into the groove must be done rapidly due to Teflon's memory characteristics. The longer the seal remains in the stretched condition the longer it takes the seal to return to its original shape.

INSTALLATION AND MAINTENANCE

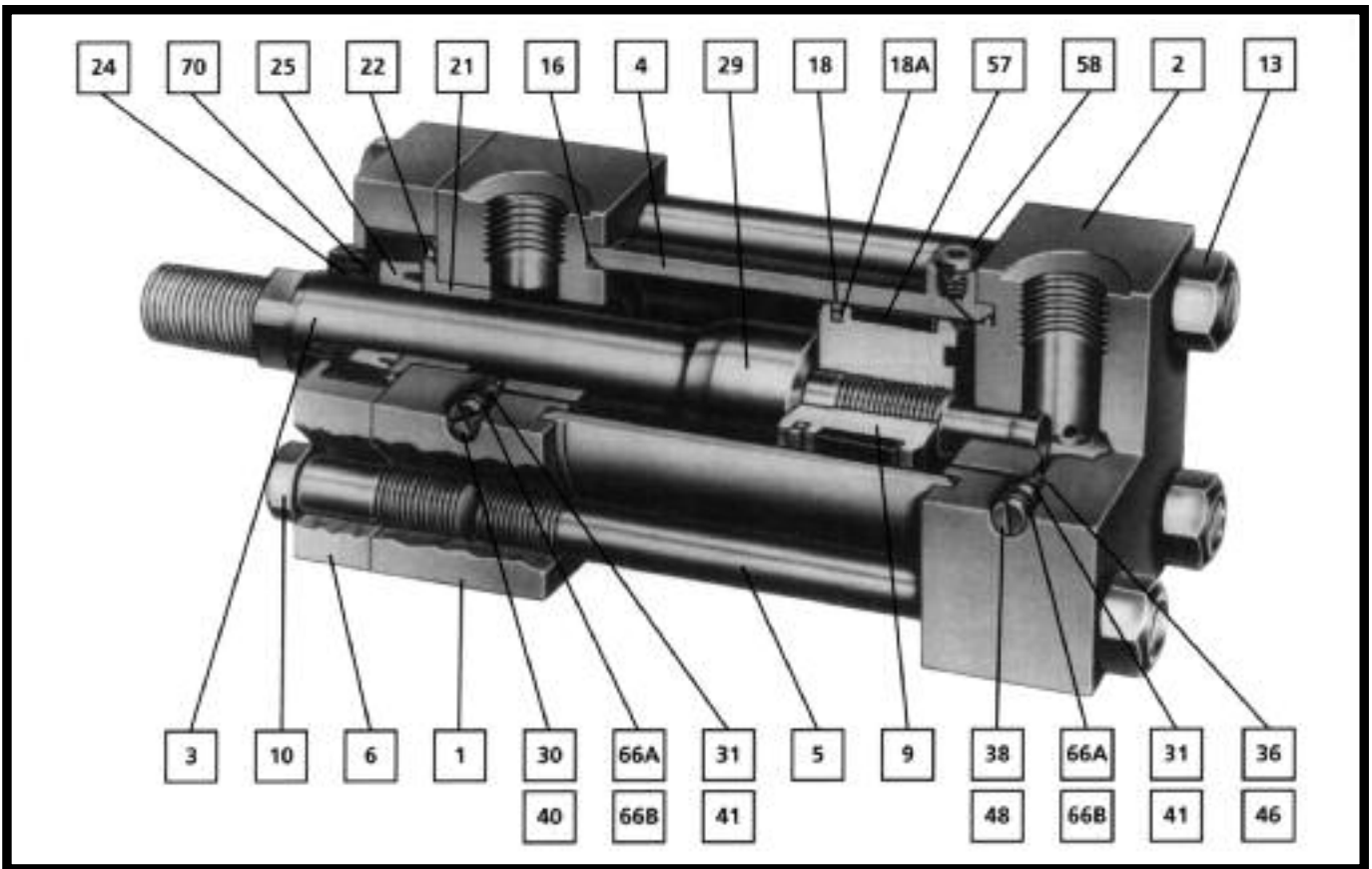

Maintenance Cont.

The piston bearing strip is a single piece that has scarfed cut ends that is simply wrapped around the piston. It is not intended that the cut ends meet to make a seal.

To replace the piston and rod assembly into the tube, the end of the piston containing the bearing strip should enter first. Lubricate the O.D. of the bearing and seal before inserting it into the tube. The piston and rod assembly should enter straight into the tube, but sometimes it is helpful to rock the component being moved up and down or sideways in order to move the piston into the tube. It may be necessary to apply a pressure on the bearing strip at the leading edge in order to get it started into the tube. To do this, use a small screwdriver with rounded edges and corners and push inward on the bearing strip (toward the centre of the piston) at the point where it is entering the tube, and at the same time pushing the piston into the tube. This procedure will be helpful when the piston seal starts to enter the tube, especially if the seal was stretched a little more than need be and has not returned completely to its proper size.

If it becomes necessary to disassemble the piston rod (item 3) and the piston (item 9), remove the piston dowel screw or screws (item 15) apply heat (approximately 230°C) to break the chemical lock, and unscrew the piston. When doing so, be careful not to scratch or otherwise damage the polished surface of the piston rod or the piston.

When replacing the piston on the rod, apply a locking sealant, such as Loctite Grade 242 to the first 3-4 threads closest to the shoulder on the rod. Follow the manufacturer's recommendations for cleaning the threads prior to application of the sealant. Tighten the piston securely using the spanner wrench holes in the rear face of the piston. **DO NOT ATTEMPT TO LINE UP ORIGINAL DOWEL SCREW HOLE.**

After tightening the piston in place, use a hand drill and relocate the dowel screw or screws in a new position. Dowel Screw size and drilling requirements:

25 and 32 bore, drill 4.2 x 10DP, half in piston and half in rod, tap M5 x 0.8p x 6 DP., bottom the dowel screw (M5 x 0.8p x 6 socket set screw).

40 through 100 bores, drill 5 x 12 DP., half in piston and half in rod tap M6 x 1p x 8 DP., bottom the dowel screw (M6 x 1p x 8 socket set screw).

125 through 200 bores, drill 8.5 x 14 DP., half in piston and half in rod, tap M10 x 1.5p x 10 DP., bottom the dowel screw (M10 x 1.5p x 10 socket set screw).

Apply Loctite Grade 242 to all dowel screw threads.

After bottoming set screw, stake set screw by centrepunching 1 1/2 mm from edge of screw deep enough to upset the first couple of threads. Staking should be done on the piston rod where possible.

When inserting the piston rod through the head, use care not to scrape the piston rod. Insert head and cap onto tube and replace the rods and tie rod nuts. Use the torque charts shown below.

The cushion check plug (item 38 or item 48) and the cushion adjusting screw (item 30 or item 40) are interchangeable on the same head, but not necessarily between the head and cap. Both adjusting screw and plug use a back-up washer (item 66A or item 66B) and an "O" ring seal (item 31 or item 41). If leakage occurs around the seal, replace the back-up washer and seal. First, place the back-up washer against the shoulder, then the "O" ring. Lubricate the seal before replacing the plug into the cavity.

Rod Gland Retainer (or Rod Gland) Screw Torque Information

Screw Torque in Newton metres			
Bore Size	Piston Rod Diameter	Hex Head Set Screw	Socket Head Cap Screw
25	ALL	7	-
32	ALL	7	-
40	ALL	14	-
50	ALL	45	-
63	ALL	45	-
80	ALL	45	7
100	ALL	45	7
125	ALL	-	14
160	70	-	14
160	110	-	18
200	90	-	14
200	140	-	18
50 (DIN)	ALL	-	7
63 (DIN)	ALL	-	7
80 (DIN)	ALL	-	14
100 (DIN)	ALL	-	14

Tie Rod Torque Information

Tie Rod 25 Through 160 Bores			
Bore	Torque in Newton metres	Bore	Torque in Newton metres
25	7	80	150
32	11	100	176
40	30	125	440
50	68	160	650
63	68	200	see table below

Tie Rod Torque for 200 Bore				
Column 1 Turn (T) in 12ths	"L" Length	One Full Turn plus T "L" Length	Two Full Turns plus T "L" Length	Three Full Turns plus T "L" Length
1	70	930	1780	2630
2	140	1000	1850	2705
3	215	1070	1920	2775
4	285	1140	1995	2845
5	355	1210	2065	2915
6	425	1280	2135	2990
7	500	1350	2205	3060
8	570	1420	2275	3130
9	640	1500	2350	3200
10	710	1565	2420	3270
11	780	1640	2490	3345
12	855	1710	2560	3415

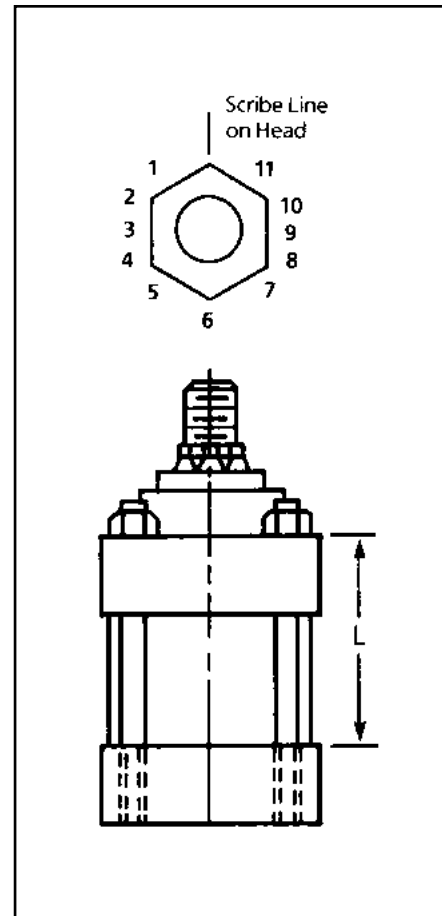

Ordering Information

When ordering parts, the following information must be specified. Model No., Serial No., Stroke, Pressure, Pressure Medium (air, oil or water) and any special features. Give item no., name and quantity of part desired. The Model No. and Serial No. will be found on a metal plate that has been drive-screwed to either the head or the cartridge retainer. For 200 bore cylinders, the tie rods are given an initial torque, and then the tie rod nuts are turned a calculated amount. First torque all 4 tie rod nuts to 270 Newton metres. Measure the cylinder to obtain length "L" as shown in the illustration. Scribe a line on the cylinder head at one point of each hex nut and a matching mark on the hex nut point. Using the derived "L" consult the chart for the proper number of turns or fractions (in 12ths). The figures in Column 1 shown in 12ths corresponds to the points and flats of the hex nut (see illustration). Tie rods should be tightened in cross corner rotation and in steps up to full tension, using an impact power wrench or a slogging type ring spanner.

PARTS LIST

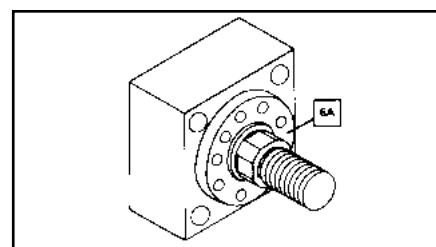
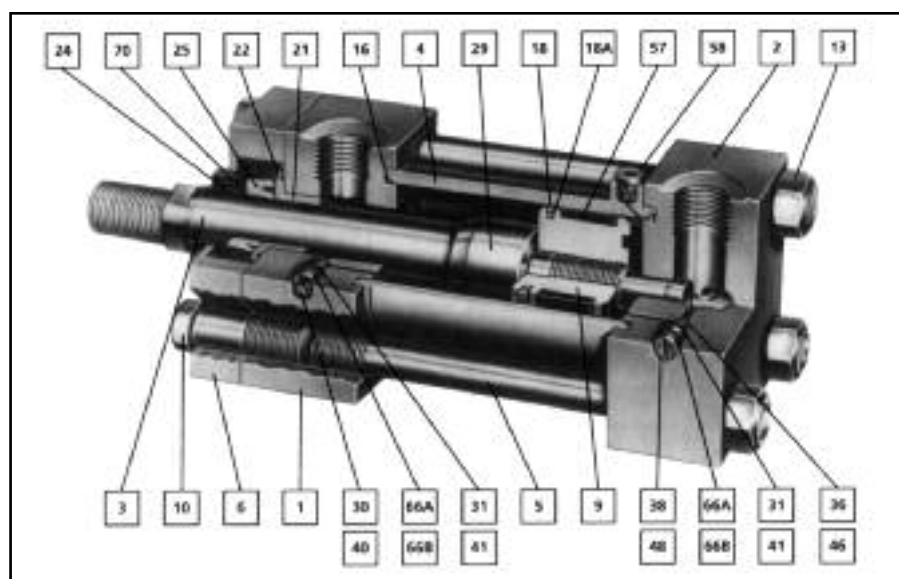

Round, Single Piece Rod Gland & Retainer used on all but some of the smaller bore sizes. Consult pages on specific mounts.

Clevis Mount

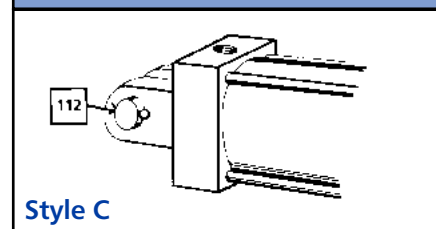

Style C

Intermediate Trunnion Mount

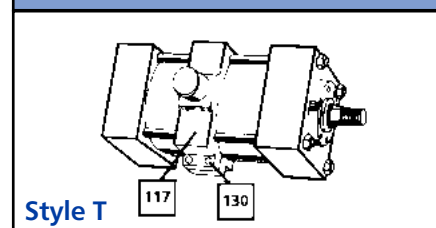

Style T

Item No.	Description	Quantity Required
1	Head	1
2	Cap	1
3	Piston Rod	1
4	Tube	1
5	Tie Rod	4
6	Rod Gland Retainer	1
6A	Rod Gland and Retainer - Single Piece	1
9	Piston - Slipper Seal Type	1
10	Retainer Screw	u
13	Tie Rod Nut	4
16=	Tube Seal	2
18=	Piston Seal - Slipper Seal	1
18A=	Expander - For Slipper Seal	1
21=	Rod Bearing	1
22=	Rod Gland Seal	1
24=	Rod Wiper/Seal	1
25=	Rod Seal	1
29	Cushion Piston - Front	**
30	Cushion Adj. Screw - Front (Cross Slot)	**
31	Seal - Cushion Adj. & Cush. Check - Front	**
36	Cushion Check Ball - Front	**
38	Cushion Check Plug - Front	**
40	Cushion Adj. Screw - Rear (Cross Slot)	**
41	Seal - Cush. Adj. & Cush. Check - Rear	**
46	Cushion Check Ball - Rear	**
48	Cushion Check Plug - Rear	**
57	Piston Bearing Strip	*
58	Air Bleed Plug	**
66A	Back-Up Wash. - Cush. Adj. & Check - Front	**
66B	Back-Up Wash. - Cush. Adj. & Check - Rear	**
70	Rod Gland	1

u Retainer screws required varies by bore and mount.
 = Recommended spare parts.

* 1 required 25 through 100 bore,
 2 required 125 through 200 bore.
 **As required; specify if cushioned front,
 cushioned rear or cushioned both ends.

Item No.	Description	Qty. Req'd.
117	Intermediate Trunnion	1
130	Intermediate Trunnion Screw	4
112	Clevis Pin	1

Complete replacement packing kits are available. For purposes of economy and less down-time, it is recommended that replacement packing kits be stocked. They are described and priced in the current Replacement Parts Price List. Contact the factory for these lists.

EH Series Cylinder Weight Chart

Bore	Zero Stroke	Add per 25mm of Stroke
	Kilograms	
25	1.5	0.12
32	2.7	0.18
40	3.7	0.23
50	7	0.37
63	9	0.60
80	17	0.82
100	23	1.15
125	41	1.90
160	64	2.70
200	132	4.10

Note:

The above weights are based on an average value for cushioning, rod size, and the various types of mountings for uncrated cylinders to establish approximate shipping weights. Add 10% of cylinder weight to determine estimate weight of crated cylinder.

Composition

Example 63	EH	FHF	250	CC	W
Bore	Cylinder Series	Mounting	Stroke	Cushion	Modification
As Required	Heavy Duty Hydraulic	Listed Below Specify Suffix 'D' for DIN mounting eg: FHFD	As Required Shown as Gross Stroke including Dual Piston or Stop Tube Length	CF – Cushion Front CR – Cushion Rear CC – Cushion both ends	A – Variation in Ports D – Double Rod Extension K – Any variation in Rod from Standard. Any variation from Standard Style 2 Rod End. M – Variation in Mounting S – Spring Return V – Viton W – Water Fitted Y – Variation in Construction

Mounting Styles ISO

- BX** – Basic Cylinder – tie rods extended – both ends
- C** – Clevis
- FHF** – Front Head Flange
- FX** – Basic cylinder – tie rods extended – front end
- NX** – Basic cylinder – no tie rod extension
- P** – Pivot
- RHF** – Rear Head Flange
- RX** – Basic cylinder – tie rods extended – rear end
- SBp** – Pivot with Spherical Bearings
- SL** – Side Lug
- T** – Trunnion – between heads
- TF** – Trunnion – front
- TR** – Trunnion – rear

Mounting Styles DIN

- FHFD** – Front Head Flange
- RHFD** – Rear Head Flange
- SBpD** – Pivot with Spherical Bearing
- SLD** – Side Lug
- TD** – Trunnion – between heads

Order Information

To insure prompt delivery, please BE SURE TO INCLUDE THIS INFORMATION WHEN ORDERING:

1. Quantity
2. Series
3. Bore
4. Stroke – always show Gross Stroke in Model Number
5. Dual Piston or Stop Tube when necessary
6. Mounting Style
7. Cushion (front, rear, both or none)
8. Rod End Style (if other than Style 2 standard)
9. Rod Size (standard, intermediate or oversize or 2:1)
10. Extra Rod Extension (where required)
11. Port Size (if other than standard)
12. Port Positions other than standard positions 1 and 5
13. Cushion check, adjusting screw, and bleed positions (when required) if other than standard positions shown on page 9.
14. Medium (air, oil, water or other)
15. Type of fluid
16. Operating Pressure and Maximum Shock Pressure
17. Temperature
18. Double rod extension (when required)
19. XI dimension on all Trunnion (between head) cylinders
20. Delivery required, or scheduling

Complete and correct ordering information will eliminate untimely delays. When in doubt always contact our factory.

Policy and Warranty

WARRANTIES AND LIABILITIES

- (a) The Company warrants that it has title to and the unencumbered right to sell the Goods and that the Goods shall remain free of defects caused by faulty design, manufacture, materials, or workmanship for the period of one year (“the Warranty Period”) from the date of despatch of the goods. For the avoidance of doubt this warranty does not extend to defects which in the reasonable opinion of the Company have been caused by abnormal use, misuse, Act of God, lightning, accident, malicious damage, neglect or alteration or repair of the goods without the Company’s written approval.
- (b) If such defects covered by the warranty as aforesaid so appear in the goods within the Warranty period then the Company shall at its own expense rectify, or at its option replace the Goods. The Company reserves the right to disclaim liability under this warranty, unless:
 - (i) the buyer informs the Company in writing within 10 working days of the same being discovered, and
 - (ii) the goods are returned at the Buyer’s risk and expense as directed by the Company.
- (c) Where defects are not covered by the Company’s warranty, then the Company reserves the right to make a charge to the Buyer at its then current rate for the rectification or replacement of the Goods.
- (d) In the case of Goods or any part thereof not of the Company’s manufacture, the Buyer shall be entitled to the benefit only of such warranty as is given to the Company in respect thereof.
- (e) The Company shall not be liable to the Buyer for any loss of profits, goodwill or any type of special indirect or consequential loss (including loss or damage suffered by the Buyer as a result of an action brought by a third party).
- (f) No claim under the Contract will entitle the Buyer to cancel any outstanding part of the Order.
- (g) The Company shall not be liable to the Buyer or be deemed to be in breach of the Contract by reason of any delay in performing or any failure to perform any of the Company’s obligations in relation to the Goods if the delay or failure was due to any cause beyond the Company’s reasonable control.
- (h) Save as expressly provided in these Conditions all warranties conditions or other terms implied by statute or common law are excluded to the fullest extent permitted by law.

SERIES LIST

MH Series

1¹/₈ (28 mm) through 8 inch (200 mm) Bore. Medium Pressure Hydraulic. Compact and dimensionally interchangeable to NFPA/JIC standards. Tapered Cushions.

HH Series

1¹/₈ (28 mm) through 24 inch (600 mm) Bore. 210-345 bar Hydraulic. Machine Tool Precision. Most easily serviced. Dimensionally interchangeable to NFPA/JIC standards.

UH Series

2 (50 mm) through 12 inch (300 mm) Bore. 345-550 bar. Hydraulic. 1-piece steel heads. Super-duty service. Tapered Cushions. Easily removed rod cartridge.

EH Series

Compact Metric to ISO 6020/2 and DIN 24554. 25mm through 200mm bore. 210 bar. Hydraulic.

ER Series

Roundline Mill Cylinder to ISO 6020/1 25mm through 200mm bore. 160 bar. Hydraulic.

Limit Switch Cylinders

Mechanical

Mechanically operated switches available on square head cylinders - 10 bar air to 210 bar. hydraulic.

Magnetic

Magnetically operated reed switches available on A, MA and C20 Series air cylinders. Ideal for timing - automatic control.

Proximity

Permanent magnet ferrous material actuated proximity switches available on square head cylinders up to 550 bar. BASEEFA approved and sub-sea models available.

MA Series

1¹/₂ (38 mm) through 8 inch (200 mm) Bore. Medium duty Air Service. Popular dimensional interchangeable mounts at economy pricing. Rated for 10 bar Air. Lubed for life. Great OEM cylinder.

A Series

1¹/₈ (28 mm) through 14 inch (356 mm) Bore. 17 bar Air. Double Acting. Adjustable Cushions. Dimensionally NFPA/JIC interchangeable.

C20 Series

1¹/₂ (38 mm) through 8 inch (200 mm) Bore. 10 bar Air. Double Acting, cushioned and non-cushioned. Economy priced.

CL Series

³/₄ (19 mm) and 1¹/₈ (28 mm) Bores. CLA for 10 bar Air Service. Heavy Duty CLH for 17 bar. Air Service or 103 bar Hydraulic Service. Double Acting and Spring Return. Universal mount with Accessories for all applications.

- m Cylinders of all sizes, for all applications, pressures and fluid mediums... in almost every price range.
- m Easily installed and serviced.
- m Compact, rugged and reliable.
- m Wide range of matched mounting accessories.
- m Custom built variations of all standard cylinders at nominal cost.
- m Cylinders to 750 mm bore in a variety of mountings and pressure ranges.

